

Safety Photoelectric Switch**E3FS-Family****Safety Design for Category 2.
Suitable for Detecting Human Bodies in Hazardous Area.****Main features**

- The E3FS is a Type 2 Safety Single Beam intended to be used with the control unit F3SP-U1P-TGR for the control system of a machine to category 2, 1 or B as defined in the European standard EN 954-1.
- Compliance with Machinery directive: No. 98/37/EC, EMC Directive: No. 89/336/EEC, EN 61496-1 (06/98) (Type 2 ESPE), and IEC61496-2 (1997) (Type 2 Active Optoelectronic Protection device).
- Approved by TÜV Product Service (Notified Body) as Type 2 ESPE (Electro-Sensitive-Protective-Equipment), Type 2 AOPD (Active Optoelectronic Protection device) and CE marking.
- Pursuing safety with high level of safety design and FMEA.
- System configuration of up to four units is possible.
- With the control unit F3SP-U1P-TGR, two different muting functions can be selected for each set of E3FS separately.
- Compact and space-saving (M18 DIN-sized threaded cylindrical housing, axial type)
- Housing materials: plastic and nickel brass
- Connection: Pre-wired and M12 plug
- High enclosure ratings (IP67)
- Sensing distance 10m



Guideline

Selection guide	3
■ DC-Switching Models	3
■ Accessories (Order Separately)	3
■ Connectors (Order Separately)	3
Ordering Information: type list	4
■ DC-Switching Models, plastic	4
■ DC-Switching Models, metal.....	4
Specification of the E3FS types	5
■ DC Switching Models	5
Engineering Data – Sensing Range	6
■ DC-Switching Models.....	6
Operating Instructions	7
■ Output Circuit.....	7
• NPN type	7
• PNP type	7
■ Timing Chart.....	8
■ Terminals/Connections.....	8
Accessories (order separately)	8
■ Mounting tools	8
Dimensions	9
• Plastic housing	9
• Metallic housing	9
Precautions on Safety	10

Selection guide

■ DC-Switching Models

		Plastic		Nickel Brass (-M)	
		Cable Type	Plug Type	Cable Type	Plug Type
Method of detection		Separate	Separate	Separate	Separate
Rated sensing distance		10m	10m	10m	10m
Operating state of output	Output configuration				
Light-ON/ Dark-ON (selectable)	PNP	E3FS-10B4	E3FS-10B4-P1	E3FS-10B4-M	E3FS-10B4-M1-M
	NPN	E3FS-10C4	E3FS-10C4-P1	E3FS-10C4-M	E3FS-10C4-M1-M





■ Accessories (Order Separately)

Name	Model
Mounting Bracket	Y92E-B18
Muting Control Unit	F3SP-U1P-TGR

For detailed information about the mounting bracket, refer to the main chapter "Accessories" at the end of the document.

For detailed information about the muting control unit, refer to the specification sheet E502-E2-01.

■ Connectors (Order Separately)

Cord	Appearance		Cord length	Model
Standard	Straight (4 conductor)		2m	XS2F-D421-D80-A
			5m	XS2F-D421-G80-A
	L-shape (4 conductor)		2m	XS2F-D422-D80-A
			5m	XS2F-D422-G80-A
Robot (vibration-proof)	Straight (4 conductor)		2m	XS2F-D421-D80-R
			5m	XS2F-D421-G80-R
	L-shape (4 conductor)		2m	XS2F-D422-D80-R
			5m	XS2F-D422-G80-R

Ordering Information: type list

■ DC-Switching Models, plastic

Pos.	Code	Sensing method, sensing distance	Connection (cable-length)	Output/ Input config.	Enclosure ratings	Comments
1	E3FS-10B4 2M	Through beam, 10m	Pre-wired (2m)*	PNP	IP67	Receiver and Emitter
2	E3FS-10C4 2M	Through beam, 10m	Pre-wired (2m)*	NPN	IP67	Receiver and Emitter
3	E3FS-10B4-P1	Through beam, 10m	Connector	PNP	IP67	Receiver and Emitter
4	E3FS-10C4-P1	Through beam, 10m	Connector	NPN	IP67	Receiver and Emitter

Note : * Other cable lengths available by special order

■ DC-Switching Models, metal

Pos.	Code	Sensing method, sensing range	Connection (cable-length)	Output/ Input config.	Enclosure ratings	Comments
1.	E3FS-10B4-M 2M	Through beam, 10m	Pre-wired (2m)*	PNP	IP67	Receiver and Emitter
2.	E3FS-10C4-M 2M	Through beam, 10m	Pre-wired (2m)*	NPN	IP67	Receiver and Emitter
3.	E3FS-10B4-M1-M	Through beam, 10m	Connector	PNP	IP67	Receiver and Emitter
4.	E3FS-10C4-M1-M	Through beam, 10m	Connector	NPN	IP67	Receiver and Emitter

Note : * Other cable lengths available by special order

Remarks to enclosure ratings:

The enclosure ratings IP67 of OMRON internal standard correspond to a higher test requirements than the official standard IEC 60 529 :

- ◆ The sensors rated IP67 have special enclosure protection. In this case, the sensors have passed the OMRON-internal heat shock test (see below) before the IP67-test of IEC 60 529 (1m water height for 1 hour). Afterwards the sensors have been tested according to the OMRON-internal waterproof-test (see below).

heat shock:

Alternating, fast temperature changes between -25°C and $+55^{\circ}\text{C}$ are executed for 5 cycles and 1 hour for each temperature. Functioning and isolation is checked afterwards.

water proof:

After the heat shock test, the sensors are exposed alternating under water of $+2^{\circ}\text{C}$ and $+55^{\circ}\text{C}$ executing 20 cycles and 1 hour for each temperature. Functioning, water tightness and electrical isolation is checked afterwards.

Specification of the E3FS types

■ DC Switching Models

Item	Emitter E3FS-10LB... E3FS-10LC...	Receiver E3FS-10DB4... E3FS-10DC4...
Method of detection	Separate	
Power supply voltage	12 to 24V DC +/- 10% (ripple (p-p) 10%)	
Current consumption (max.)	50mA	25mA
Rated sensing distance	10m (Function reserve: +20%)	
Standard object	Opaque 11 mm min.	
Operation angle	+/- 5° (at 3m)	
Response time	2.0ms	
Control output	Transistor output PNP or NPN 100mA max residual voltage: 2V max at 100mA (for PNP and NPN type)	
Test input (Emitter)	E3FS-10B ___ (PNP)	Vcc to Vcc-2,5V : Emitting OFF (Sink current: 3mA max.) Open or 0 to 2,5V: Emitting ON (Leakage current: 0,1mA max.)
	E3FS-10C ___ (NPN)	0 to 2,5V : Emitting OFF (Source current: 3mA max.) Open or Vcc to Vcc-2,5V: Emitting ON (Leakage current: 0,1mA max.)
Mode selection input (Receiver)	Connection to Vcc: Light ON (ON when incident) Connection to 0V: Dark ON (ON when interrupt)	
Power reset time	100ms	
Ambient illumination	Incandescent lamp: 3000 lx max Sunlight: 10000 lx max	
Ambient temperature [9]	Operating: -25 to 55°C; Storage: -30 to 70°C	
Ambient humidity	Operating: 35% to 95%; Storage: 35% to 95%	
Insulation resistance	20MΩ min. at 500V DC between current carrying parts and case	
Dielectric strength	1000V AC, 50/60Hz for 1 min between current carrying parts and case	
Vibration resistance	Durability	10 to 55 Hz, 1,5mm double amplitude, each X, Y, Z direction 2 hours
	Operation Limit	10 to 55 Hz, 0,7mm double amplitude, each X, Y, Z direction 50min
Shock resistance	Durability	500m/s ² (approx. 50 g) each X, Y, Z direction for 3 times
	Operation limit	100m/s ² (approx. 10 g) each X, Y, Z directions for 1,000 times
Enclosure ratings	IP67	
Light source	Infrared	
Indicators	Emitter: Orange / Light emission Receiver: Green / ON-state, Red / OFF-state	
Sensitivity adjustment	Fixed	
Connection method	2m pre-wired cable or connector	
Operation mode	Light-ON or Dark-ON selectable by wiring	
Weight for set	Pre-wired cable models: Plastic case Approx. 150 g Metal case Approx. 205 g	Connector models: Approx. 55 g Approx. 125 g
Circuit protection	Output short-circuit and power supply reverse polarity	
Housing materials	Plastic	Nickel brass

Engineering Data – Sensing Range

■ DC-Switching Models

→ Through-beam type (E3FS-104-)

Sensing Range

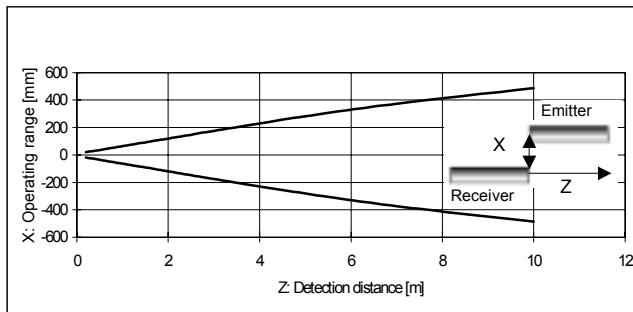

Mutual Interference Range

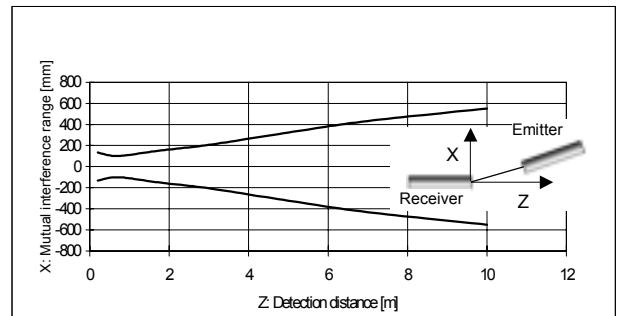

Excess Gain Ratio

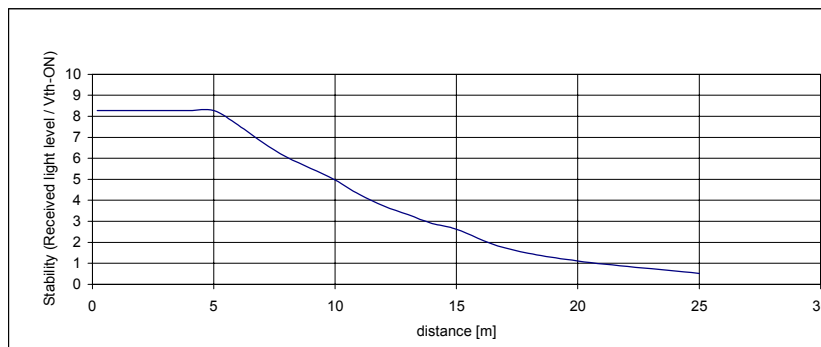

Operating Instructions

■ Output Circuit

• NPN type

Model	Connection method	Output transistor	Output circuit
E3FS-10DC4 2M E3FS-10DC4-P1 E3FS-10DC4-M 2M E3FS-10DC4-M1-M Receiver circuit	Connect the pink and brown cords.	ON when light is incident. (Light-ON)	
	Connect the pink and blue cords.	ON when light is interrupted. (Dark-ON)	
E3FS-10LC 2M E3FS-10LC-P1 E3FS-10LC-M 2M E3FS-10LC-M1-M Emitter circuit			

• PNP type

Model	Connection method	Output transistor	Output circuit
E3FS-10DB4 2M E3FS-10DB4-P1 E3FS-10DB4-M 2M E3FS-10DB4-M1-M Receiver circuit	Connect the pink and brown cords.	ON when light is incident. (Light-ON)	
	Connect the pink and blue cords.	ON when light is interrupted. (Dark-ON)	
E3FS-10LB 2M E3FS-10LB-P1 E3FS-10LB-M 2M E3FS-10LB-M1-M Emitter circuit			

■ Timing Chart

Output mode and timing chart

Receiver connection		Connect Pink (2) to Brown(1).	Connect Pink (2) to Blue (3).
Mode of output		ON when Incident (Light ON)	ON when interrupted (Dark ON)
Light Incident			
Light interrupted			
Indicator	Green		
	Red		
Control output	ON		
	OFF		
Load (Relay)	ON		
	OFF		

Emitting timing Chart

		Timing chart
Test input	ON OFF	
Light emission	ON OFF	
Indicator	ON OFF	

■ Terminals/Connections

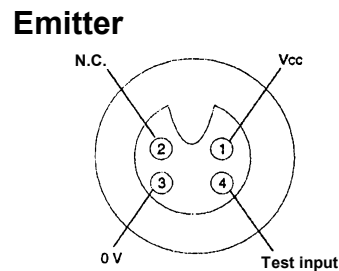
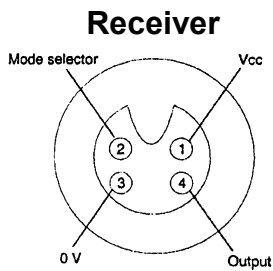

Accessories (order separately)

■ Mounting tools

Y92E-B18 Mounting Bracket

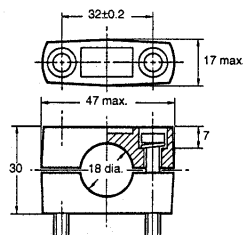
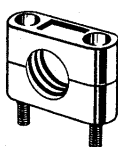

Note: Hexagonal bolt: M5 x 32
Material: plastic

Dimensions

• Plastic housing

Cable type:

E3FS-10LB
E3FS-10DB4
E3FS-10LC
E3FS-10DC4

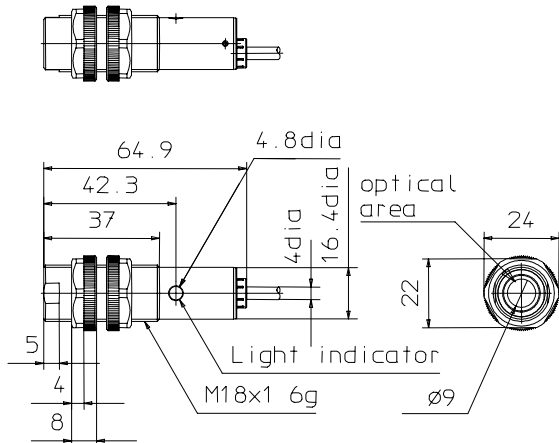

Note: All units are in millimeters unless otherwise indicated

Connector type:

E3FS-10LB-P1
E3FS-10DB4-P1
E3FS-10LC-P1
E3FS-10DC4-P1

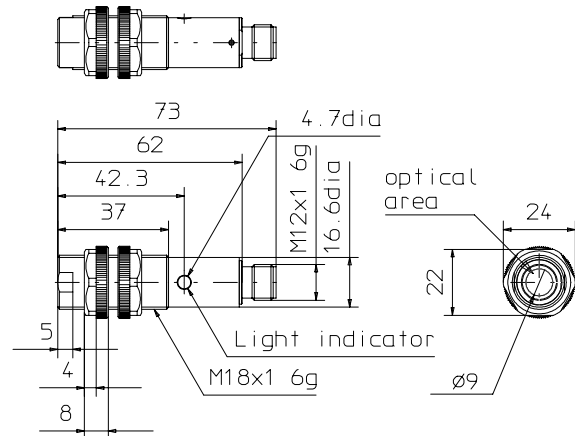

• Metallic housing

Cable type:

E3FS-10LB-M
E3FS-10DB4-M
E3FS-10LC-M
E3FS-10DC4-M

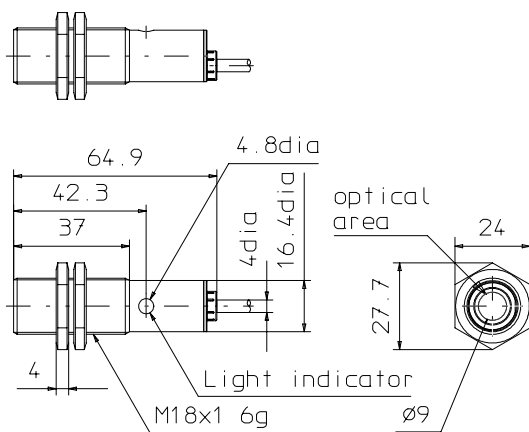

Connector type:

E3FS-10LB-M1-M
E3FS-10DB4-M1-M
E3FS-10LC-M1-M
E3FS-10DC4-M1-M

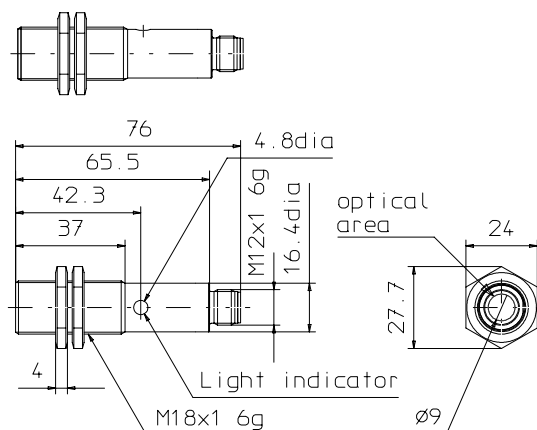

Precautions on Safety

WARNING	Indicates a potentially hazardous situation which, if not avoided, could result in death or serious injury.
	Indicates prohibited actions.

WARNING	
	When the E3FS is used without a safety control unit, do not use the E3FS as a safety device nor a part of safety systems for ensuring safety of persons.

When the E3FS is used without a safety control unit like the F3SP-U1P-TGR, it is in accordance with the requirements of the safety related control system to category B as defined in the European standard EN954-1.

The E3FS is in accordance with the requirements of the safety related control system to category 2 only when it is connected with a specified control unit.

E3FS-10B (PNP) : Type F3SP-U1P-TGR safety control unit must be used.

The F3SP-U1P-TGR executes a periodic test every 27 ms.

E3FS-10C (NPN) : Please ask OMRON about requirements for a specified control unit.

WARNING	
Make sure that personnel operating the E3FS are knowledgeable about the machine on which it is installed. Read this manual and the control unit manual completely. Be sure the information provided is understood before attempting to operate the E3FS.	
Plural E3FSs must be sufficiently far from each other to avoid mutual interference.	
Regarding the calculation of the safety distance, obey the control unit manual and/or related standards, e.g. EN999 when the E3FS is used as a safety device.	
Regarding the avoidance of malfunction caused by shiny surface, obey the control unit manual when the E3FS is used as a safety device.	
Use an opaque test piece with 11 mm in diameter and 200 mm or greater in effective length to check the detection capability.	
Do not connect the E3FS to an AC or DC power supply with higher voltage than nominal 24 VDC. Otherwise the sensor may explode, burn, or cause electric shock. The power supply must conform to regulatory requirements and standards, regarding EMC and electrical equipment safety, of the country where the E3FS is installed. For example, the power supply must fulfil EN60742 requirements for double insulation and must conform to EMC Directive and Low Voltage Directive in EU.	
NOTICE	
A load must not be shorted. A load must not be used with current higher than the rating. Do not apply the reversed supplied voltage. Be sure to route the E3FS cable separated from high-potential power line or through an exclusive conduit.	
E3FS must not be used in water.	
The E3FS is ready to operate 100ms after the E3FS is turned ON. If the load and E3FS are connected to independent power supplies respectively, be sure to turn ON the sensor before turning the load ON.	
To extend the cable, use a wire of 0.3mm ² or more. However do not extend it more than 50m.	
Do not use the E3FS in explosive or flammable gas.	
Do not disassemble, repair, and modify the E3FS.	
Do not exceed a torque of 2.0N·m (20Kgf·cm) when tightening mounting nuts for plastic models 20.0N·m (200Kgf·cm) when tightening mounting nuts for metal models.	
For connector type of E3FS, make sure the cable connector is rated IP54 or higher. Be sure to connect or disconnect the connector after turning OFF the E3FS. Hold the connector cover to connect or disconnect the connector. Secure the connector cover by hand. Do not use any pliers. The proper tightening torque range should be checked according to connector specification. Be sure to tighten the connector securely.	

ALL DIMENSIONS SHOWN ARE IN MILLIMETERS.

To convert millimeters into inches, multiply by 0.03937. To convert grams into ounces, multiply by 0.03527.

Cat. No.: E508-E2-01