

# Stepping Relay Unit G9B

## Ideal for Controlling Pumps and Production Lines with Six or Twelve Stepping Circuits

- Built-in relays switch 2 A at 250 VAC or 30 VDC.
- Initialization of stepping with reset input.
- Uses memory that stores setting status for 10 days without power. All internal contacts are released when no power is supplied.
- Detects an internal element malfunction caused by external noise, indicates the malfunction with an alarm indicator, and turns the relay alarm output ON. (An internal relay malfunction or internal relay contact weld cannot be detected.)
- With safety-design terminals which prevent electric shock accidents.
- With easy-to-see indicators which display the stepping status.



## Ordering Information

No. of steps	Rated voltage	Model
6	24 VDC	G9B-06
	100 VAC	
	200 VAC	
12	24 VDC	G9B-12
	100 VAC	
	200 VAC	

**Note:** When ordering specify the voltage.  
 Example: G9B-06 24 VDC  
└─── Rated voltage

## Model Number Legend

G9B-  
└─── 1

### 1. No. of steps

- 06: 6 steps
- 12: 12 steps

# Specifications

## ■ Contact Ratings

Load	Resistive load ( $\cos\phi = 1$ )
Rated load	2 A at 250 VAC/30 VDC
Rated carry current	2 A
Max. switching voltage	250 VAC, 30 VDC
Max. switching current	2 A

## ■ Characteristics

Operating voltage range	85% to 110% of rated voltage
Power consumption	24 VDC:90 mA max. 100 or 200 VAC:120 mA max.
Contact resistance (See note 2.)	100 m $\Omega$ max.
Operate time (See note 3.)	50 ms max.
Release time (See note 3.)	50 ms max.
Min. pulse time	100 ms max.
Error detecting time	100 ms max.
Insulation resistance (at 500 VDC)	100 M $\Omega$ min. between the power supply, control, output, and R terminals 100 M $\Omega$ min. between the terminals, except the alarm output terminals and power output terminals
Dielectric strength	1,500 V, 50/60 Hz for 1 min between the power supply, control, output, and R and other terminals 1,500 V, 50/60 Hz for 1 min between the terminals, except the alarm output terminals and power output terminals
Noise immunity	Noise level: 1.5 kV, pulse width: 50 ns/1 $\mu$ s (600 V for 24-VDC model)
Vibration resistance	Destruction: 10 to 55 to 10 Hz, 0.75-mm single amplitude (1.5 mm double amplitude) Malfunction: 10 to 55 to 10 Hz, 0.75-mm single amplitude (1.5 mm double amplitude)
Shock resistance	Destruction: 500 m/s <sup>2</sup> Malfunction: 200 m/s <sup>2</sup>
Endurance	Mechanical: 10,000,000 steps min. Electrical: 300,000 steps min. (See note 4.)
Error rate (See note 5.)	10 mA at 5 VDC
Ambient temperature	Operating: -25°C to 55°C (with no icing or condensation)
Ambient humidity	Operating: 5% to 85%
Terminal strength	Tightening torque: 0.98 N • m Tensile strength: 49 N
Weight	Twelve-step model: approx. 450 g; Six-step model: approx. 400 g

**Note:** 1. The data shown above are initial values.

2. The contact resistance was measured with 0.1 A at 5 VDC using the fall-of-potential method.

3. The operate time and release time was measured with the rated voltage imposed with any contact bounce ignored at an ambient temperature of 23°C.

4. The electrical endurance was measured at an ambient temperature of 23°C.

5. This value was measured at a switching frequency of 120 operations per minute.

# Nomenclature

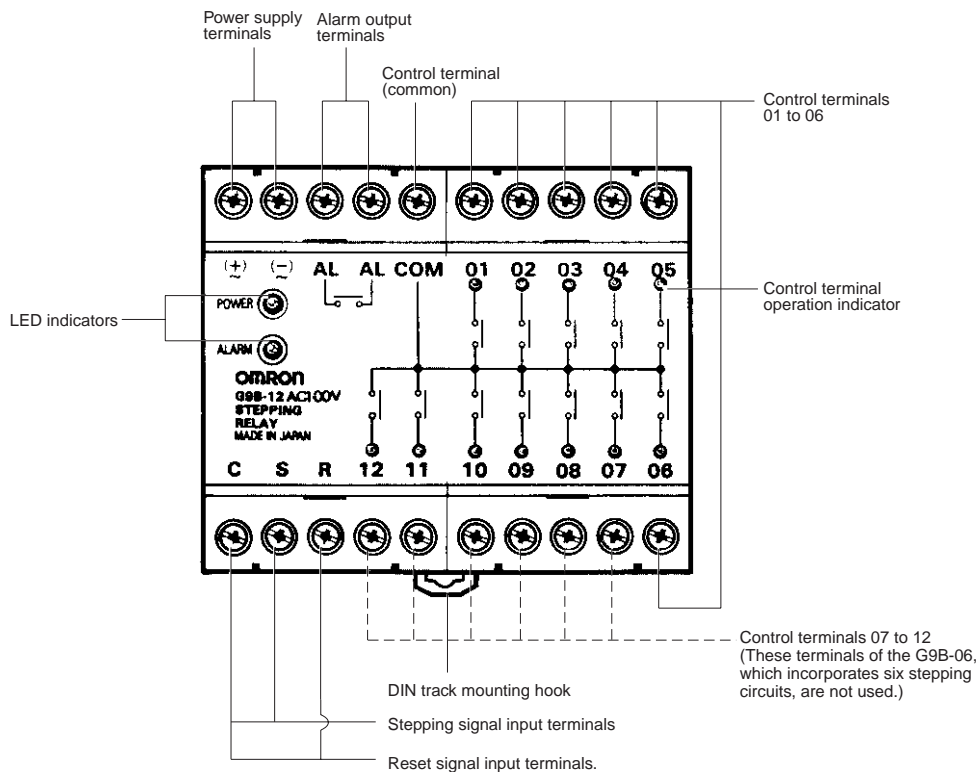

Display		Description
POWER	Lit	Lit when power is supplied to the G9B and the G9B is ready to operate or in operation.
	Not lit	Not lit when power is not supplied to the G9B.
ALARM	Lit	Lit when there is a control contact error (i.e., when a built-in relay driving element is malfunctioning).
	Not lit	Lit when the G9B is in normal operation.

# Operation

## ■ Timing Chart

### Normal Operation with No Reset Signal

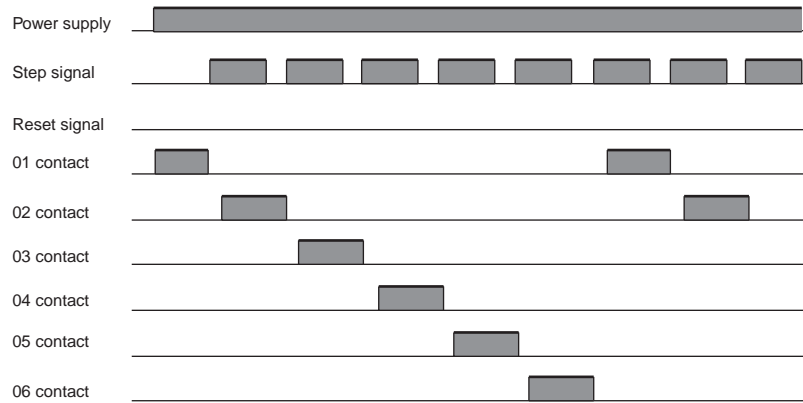

A different contact is selected in numerical order per step signal pulse. When the contact currently selected is 06, 01 will be selected with the next step signal input.

### Normal Operation with Reset Signal

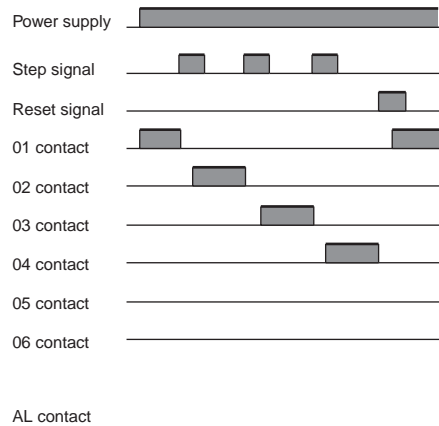

The G9B switches an active control terminal over to another control terminal and makes it active whenever the G9B receives a single step input pulse. If a reset signal is input to a control terminal of the G9B when the G9B is in stepping operation, terminal 1 of the G9B will become active.

### Emergency Case (ON Error)

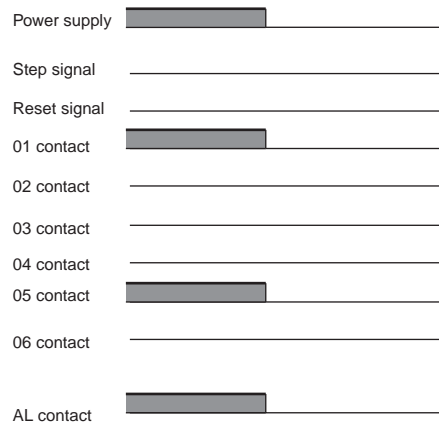

If an internal contact of the G9B is incorrectly turned ON by the internal relay driving element that drives the internal contact due to external noise, the G9B will reset itself to its default status (i.e., contact 01 of the G9B will be turned ON) and turn its alarm contact ON so that the ALARM indicator of the G9B will become lit. When the G9B is turned OFF, the alarm contact will turn OFF and the ALARM indicator will not be lit. In this example, contact 05 is incorrectly turned ON.

**Emergency Case (ON Error)**

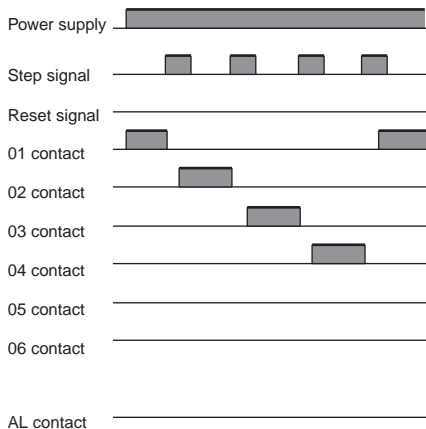

If an internal contact of the G9B is incorrectly turned OFF by the internal relay driving element that drives the internal contact due to external noise, the G9B will reset itself to its default status (i.e., contact 01 of the G9B will be turned ON) when the internal contact incorrectly turned OFF becomes active. In this example, contact 05 is incorrectly turned OFF.

**Dimensions**

**Note:** All units are in millimeters unless otherwise indicated.

**G9B-06**

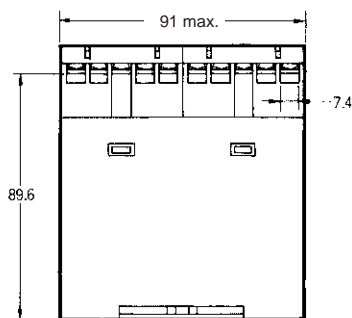
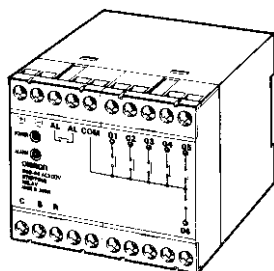

**G9B-12**

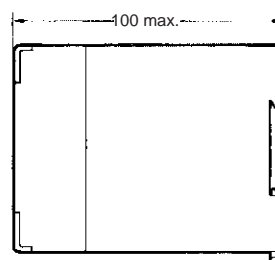
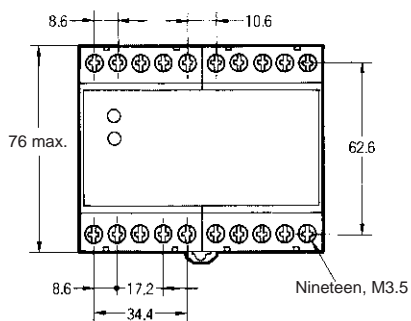
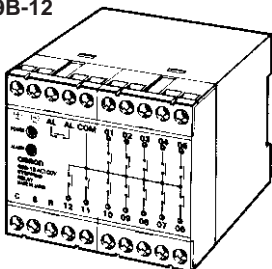

# Installation

## Internal Circuit

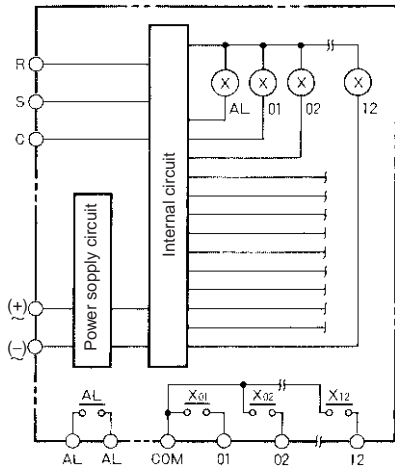

## Terminal Arrangement

G9B-06

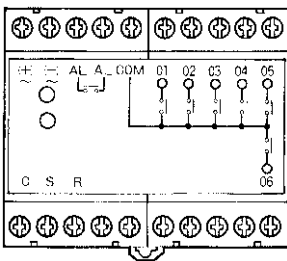

G9B-12

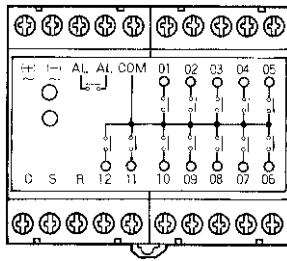

## Input Connections

The inputs of the G9B are no-voltage (short-circuited or open) inputs.

### No-contact Input

(Connection to NPN open collector output sensor.)

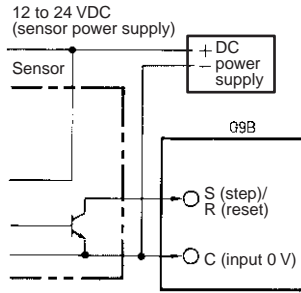

Operates with transistor ON

### Contact Input

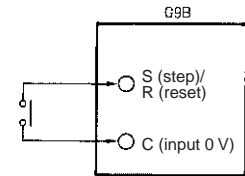

Operates with relay ON

## No-voltage Input Signal Level

No-contact input	<ol style="list-style-type: none"> <li>Short-circuit Level (transistor ON) Residual voltage: 1 V max. Impedance when ON: 1 kΩ max.</li> <li>Open Level (transistor OFF) Impedance when OFF: 100 kΩ max.</li> </ol>
Contact input	Use contacts which can adequately switch 3 mA at 24 VDC

- Note:**
- Two-wire sensors cannot be used.
  - When using three-wire sensors, only NPN open-collector models can be used.

## Precautions

Refer to page 11 for general precautions.

## Memory Backup Function

The G9B has a built-in memory that stores the setting status for 10 days without power. All contacts are released when no power is supplied. When the G9B is turned ON again, the internal contacts will be set to the previous setting status.

When power is not supplied, the output contacts will turn OFF. If a reset signal is input while power is not being supplied, the next step will be step 01 when power is restored.

When 24 VDC is supplied to the G9B, make sure that the polarity of the power is correct.

ALL DIMENSIONS SHOWN ARE IN MILLIMETERS.

To convert millimeters into inches, multiply by 0.03937. To convert grams into ounces, multiply by 0.03527.