

Multifunction safety light curtain, programmable via setting console

- Complies with EN61496 Type 4, applicable up to category 4 in according with EN954-1
- Series connection with master and slave possible (max. 3 sets)
- Finger or hand protection (other on request)
- Minimum housing cross-section (30mm x 30mm)
- No blind zone for hand protection devices
- Functions which can be set via setting console:
 - Blanking function, fixed or moveable
 - Start/restart interlock
 - Auxiliary output with 7 different operation modes
 - Device monitoring
 - Interlock function
- Version with 4 beams and 300 mm beam gap:
F3SH





F3SN-A/F3SH-A Safety Light Curtain/Multi-beam Safety Sensor

■ Available Models

◆ Specification

● Safety Light Curtain

Infrared

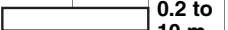
Detection capability	Beam gap	Appearance	Operating range	No. of beams	Protective height	Connector for series-connection	Model *1
14 mm-dia.	9 mm			21 to 125 (odd numbers only)	Every 18 mm from 189 to 1,125 mm	No	F3SN-A□□□□P14
						Yes	F3SN-A□□□□P14-01 ^{*2}
25 mm-dia.	15 mm			13 to 120	Every 25 mm from 217 to 1,822 mm	No	F3SN-A□□□□P25
						Yes	F3SN-A□□□□P25-01

*1. The □□□□ in the model numbers indicates the protective height (in mm).

*2. F3SN-A □□□□ P14-01 is a customized model produced at the OMRON plant.
Consult with your dealer or OMRON representative when ordering this model.

● Multi-beam Safety Sensor

Infrared

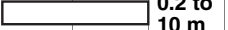
Beam gap	Appearance	Operating range	No. of beams	Outermost-beam gap	Connector for series-connection	Model
300 mm			4	900 mm	No	F3SH-A09P03
					Yes	F3SH-A09P03-01

◆ Accessories (Optional)

● Control unit

Appearance	Output	Model
	Relay, 3NO + 1NC	F3SP-B1P

● Setting console

Appearance	Model	Accessories
	F39-MC11	One branching connector, One connector cap, 2-m cable, Instruction manual

Available Models

Accessories (Optional)

Single-ended connector cable (for Emitter and Receiver set)

Appearance	Cable length	Specification	Model
	3 m	M12 connector (8 pins)	F39-JC3A
	7 m		F39-JC7A
	10 m		F39-JC10A
	15 m		F39-JC15A

Double-ended connector cable (for Emitter and Receiver set)

Appearance	Cable length	Specification	Model	Application
	0.2 m	M12 connector (8 pins)	F39-JCR2B	Series connection or connection with F3SP-B1P
	3 m		F39-JC3B	
	7 m		F39-JC7B	Connection with F3SP-B1P *
	10 m		F39-JC10B	
	15 m		F39-JC15B	

* Cannot be used for series-connection purpose.

External indicators (Separate models for Emitters and Receivers)

Appearance	Specification	Indicator	Type	Model
	M12 connector for PNP output	Red	Emitter	F39-A01PR-L
			Receiver	F39-A01PR-D
		Green	Emitter	F39-A01PG-L
			Receiver	F39-A01PG-D

Spatter protection cover (Includes two pieces for Emitter and Receiver)

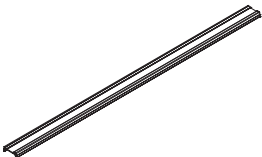
Appearance	Applicable Models	Model *
	F3SN-A□□□□P14	F39-HN□□□□-14
	F3SN-A□□□□P25 F3SN-A□□□□P25-01	F39-HN□□□□-25
	F3SH-A09P03	F39-HH09-03

* The same 4-digit numbers as the protective heights (□□□□ in the light curtain type names) are substituted by □□□□ in the type names.

Mirror (Reduces operating range by 12% with each unit)

Mirror material	Width (mm)	Depth (mm)	Length (mm)	Model
Glass Mirror	145	32	406	F39-MLG0406
			610	F39-MLG0610
			711	F39-MLG0711
			914	F39-MLG0914
			1,067	F39-MLG1067
			1,219	F39-MLG1219
			1,422	F39-MLG1422
			1,626	F39-MLG1626
			1,830	F39-MLG1830
			2,134	F39-MLG2134

F3SN-A/F3SH-A Safety Light Curtain/Multi-beam Safety Sensor

■ Safety Light Curtain

● F3SN-A□□□□P14, F3SN-A□□□□P14-01

Model	Protective height	No. of beams
F3SN-A0189P14(-01)	189	21
F3SN-A0207P14(-01)	207	23
F3SN-A0225P14(-01)	225	25
F3SN-A0243P14(-01)	243	27
F3SN-A0261P14(-01)	261	29
F3SN-A0279P14(-01)	279	31
F3SN-A0297P14(-01)	297	33
F3SN-A0315P14(-01)	315	35
F3SN-A0333P14(-01)	333	37
F3SN-A0351P14(-01)	351	39
F3SN-A0369P14(-01)	369	41
F3SN-A0387P14(-01)	387	43
F3SN-A0405P14(-01)	405	45
F3SN-A0423P14(-01)	423	47
F3SN-A0441P14(-01)	441	49
F3SN-A0459P14(-01)	459	51
F3SN-A0477P14(-01)	477	53
F3SN-A0495P14(-01)	495	55

Model	Protective height	No. of beams
F3SN-A0513P14(-01)	513	57
F3SN-A0531P14(-01)	531	59
F3SN-A0549P14(-01)	549	61
F3SN-A0567P14(-01)	567	63
F3SN-A0585P14(-01)	585	65
F3SN-A0603P14(-01)	603	67
F3SN-A0621P14(-01)	621	69
F3SN-A0639P14(-01)	639	71
F3SN-A0657P14(-01)	657	73
F3SN-A0675P14(-01)	675	75
F3SN-A0693P14(-01)	693	77
F3SN-A0711P14(-01)	711	79
F3SN-A0729P14(-01)	729	81
F3SN-A0747P14(-01)	747	83
F3SN-A0765P14(-01)	765	85
F3SN-A0783P14(-01)	783	87
F3SN-A0801P14(-01)	801	89
F3SN-A0819P14(-01)	819	91

Model	Protective height	No. of beams
F3SN-A0837P14(-01)	837	93
F3SN-A0855P14(-01)	855	95
F3SN-A0873P14(-01)	873	97
F3SN-A0891P14(-01)	891	99
F3SN-A0909P14(-01)	909	101
F3SN-A0927P14(-01)	927	103
F3SN-A0945P14(-01)	945	105
F3SN-A0963P14(-01)	963	107
F3SN-A0981P14(-01)	981	109
F3SN-A0999P14(-01)	999	111
F3SN-A1017P14(-01)	1,017	113
F3SN-A1035P14(-01)	1,035	115
F3SN-A1053P14(-01)	1,053	117
F3SN-A1071P14(-01)	1,071	119
F3SN-A1089P14(-01)	1,089	121
F3SN-A1107P14(-01)	1,107	123
F3SN-A1125P14(-01)	1,125	125

● F3SN-A□□□□P25, F3SN-A□□□□P25-01

Model	Protective height	No. of beams
F3SN-A0217P25(-01)	217	13
F3SN-A0232P25(-01)	232	14
F3SN-A0247P25(-01)	247	15
F3SN-A0262P25(-01)	262	16
F3SN-A0277P25(-01)	277	17
F3SN-A0292P25(-01)	292	18
F3SN-A0307P25(-01)	307	19
F3SN-A0322P25(-01)	322	20
F3SN-A0337P25(-01)	337	21
F3SN-A0352P25(-01)	352	22
F3SN-A0367P25(-01)	367	23
F3SN-A0382P25(-01)	382	24
F3SN-A0397P25(-01)	397	25
F3SN-A0412P25(-01)	412	26
F3SN-A0427P25(-01)	427	27
F3SN-A0442P25(-01)	442	28
F3SN-A0457P25(-01)	457	29
F3SN-A0472P25(-01)	472	30
F3SN-A0487P25(-01)	487	31
F3SN-A0502P25(-01)	502	32
F3SN-A0517P25(-01)	517	33
F3SN-A0532P25(-01)	532	34
F3SN-A0547P25(-01)	547	35
F3SN-A0562P25(-01)	562	36
F3SN-A0577P25(-01)	577	37
F3SN-A0592P25(-01)	592	38
F3SN-A0607P25(-01)	607	39
F3SN-A0622P25(-01)	622	40
F3SN-A0637P25(-01)	637	41
F3SN-A0652P25(-01)	652	42
F3SN-A0667P25(-01)	667	43
F3SN-A0682P25(-01)	682	44
F3SN-A0697P25(-01)	697	45
F3SN-A0712P25(-01)	712	46
F3SN-A0727P25(-01)	727	47
F3SN-A0742P25(-01)	742	48

Model	Protective height	No. of beams
F3SN-A0757P25(-01)	757	49
F3SN-A0772P25(-01)	772	50
F3SN-A0787P25(-01)	787	51
F3SN-A0802P25(-01)	802	52
F3SN-A0817P25(-01)	817	53
F3SN-A0832P25(-01)	832	54
F3SN-A0847P25(-01)	847	55
F3SN-A0862P25(-01)	862	56
F3SN-A0877P25(-01)	877	57
F3SN-A0892P25(-01)	892	58
F3SN-A0907P25(-01)	907	59
F3SN-A0922P25(-01)	922	60
F3SN-A0937P25(-01)	937	61
F3SN-A0952P25(-01)	952	62
F3SN-A0967P25(-01)	967	63
F3SN-A0982P25(-01)	982	64
F3SN-A0997P25(-01)	997	65
F3SN-A1012P25(-01)	1,012	66
F3SN-A1027P25(-01)	1,027	67
F3SN-A1042P25(-01)	1,042	68
F3SN-A1057P25(-01)	1,057	69
F3SN-A1072P25(-01)	1,072	70
F3SN-A1087P25(-01)	1,087	71
F3SN-A1102P25(-01)	1,102	72
F3SN-A1117P25(-01)	1,117	73
F3SN-A1132P25(-01)	1,132	74
F3SN-A1147P25(-01)	1,147	75
F3SN-A1162P25(-01)	1,162	76
F3SN-A1177P25(-01)	1,177	77
F3SN-A1192P25(-01)	1,192	78
F3SN-A1207P25(-01)	1,207	79
F3SN-A1222P25(-01)	1,222	80
F3SN-A1237P25(-01)	1,237	81
F3SN-A1252P25(-01)	1,252	82
F3SN-A1267P25(-01)	1,267	83
F3SN-A1282P25(-01)	1,282	84

Model	Protective height	No. of beams
F3SN-A1297P25(-01)	1,297	85
F3SN-A1312P25(-01)	1,312	86
F3SN-A1327P25(-01)	1,327	87
F3SN-A1342P25(-01)	1,342	88
F3SN-A1357P25(-01)	1,357	89
F3SN-A1372P25(-01)	1,372	90
F3SN-A1387P25(-01)	1,387	91
F3SN-A1402P25(-01)	1,402	92
F3SN-A1417P25(-01)	1,417	93
F3SN-A1432P25(-01)	1,432	94
F3SN-A1447P25(-01)	1,447	95
F3SN-A1462P25(-01)	1,462	96
F3SN-A1477P25(-01)	1,477	97
F3SN-A1492P25(-01)	1,492	98
F3SN-A1507P25(-01)	1,507	99
F3SN-A1522P25(-01)	1,522	100
F3SN-A1537P25(-01)	1,537	101
F3SN-A1552P25(-01)	1,552	102
F3SN-A1567P25(-01)	1,567	103
F3SN-A1582P25(-01)	1,582	104
F3SN-A1597P25(-01)	1,597	105
F3SN-A1612P25(-01)	1,612	106
F3SN-A1627P25(-01)	1,627	107
F3SN-A1642P25(-01)	1,642	108
F3SN-A1657P25(-01)	1,657	109
F3SN-A1672P25(-01)	1,672	110
F3SN-A1687P25(-01)	1,687	111
F3SN-A1702P25(-01)	1,702	112
F3SN-A1717P25(-01)	1,717	113
F3SN-A1732P25(-01)	1,732	114
F3SN-A1747P25(-01)	1,747	115
F3SN-A1762P25(-01)	1,762	116
F3SN-A1777P25(-01)	1,777	117
F3SN-A1792P25(-01)	1,792	118
F3SN-A1807P25(-01)	1,807	119
F3SN-A1822P25(-01)	1,822	120

■ Ratings and Performance (For details, refer to the instruction manual.)

◆ Specification

Item	Type	Stand-alone	F3SN-A□□□□P14 *1	F3SN-A□□□□P25 *1	F3SH-A09P03
		Series connection	F3SN-A□□□□P14-01 *7	F3SN-A□□□□P25-01 *1	F3SH-A09P03-01
Operating range			0.2 to 7.0 m	0.2 to 10.0 m	
Beam gap (P)			9 mm	15 mm	300 mm
No. of beams (n)			21 to 125 (odd numbers only)	13 to 120	4
Protective height (PH)			189 to 1125 mm PH = n × P	217 to 1822 mm PH = (n-1) × P + 37	—
Outermost beam gap			—	—	900 mm
Detection capability			Non-transparent: 14 mm in diameter	Non-transparent: 25 mm in diameter	—
Effective aperture angle (EAA)			Within ±2.5° for the emitter and receiver at a detection distance of at least 3 m according to IEC 61496-2		
Light source (luminous wavelength)			Infrared LED (870 nm)		
Supply voltage (Vs)			24 VDC ±10% (ripple p-p 10% max.)		
Current consumption (under no-load conditions)	Emitter		Up to 50 beams: 140 mA max., 51 to 85 beams:155 mA max., 86 beams and more: 170 mA max.		140 mA max.
	Receiver		Up to 50 beams: 100 mA max., 51 to 85 beams:110 mA max., 86 beams and more: 120 mA max		100 mA max.
OSSD			Two PNP transistor outputs, load current 300 mA max., residual voltage 2 V max. (except for voltage drop due to cable extension)		
Auxiliary output (Non-safety output)			One PNP transistor output, load current 50 mA max., residual voltage 2 V max. (except for voltage drop due to cable extension)		
External indicator output (Non-safety output) *2			One PNP transistor output, load current 40 mA max., residual voltage 2 V max. (except for voltage drop due to cable extension)		
Output operation mode			OSSD output: Light-ON Auxiliary output: Dark-ON (can be changed by the F39-MC11) External indicator output: Light-ON (can be changed by the F39-MC11) *2		
Test functions			<ul style="list-style-type: none"> • Self-test (After power ON, and during operation) • External test (Light emission stop function by test input) 		
Mutual interference prevention function *2			<ul style="list-style-type: none"> • Number of series connected light curtains: Up to 3 sets • Number of beams: Up to 240 beams • Length of the series connection cable: 3 m max. 		
Safety-related functions			<ul style="list-style-type: none"> • Auto reset / manual reset (Interlock function) *3 • EDM (External device monitoring) • Fixed blanking *4 • Floating blanking *4 		<ul style="list-style-type: none"> • Auto reset / manual reset (Interlock function) *3 • EDM (External device monitoring)
Protection			Output short-circuit protection, Reverse polarity protection		
Response time (under stable light incident condition)			ON to OFF: 10 ms to 15.5 ms max. OFF to ON: 40 ms to 62 ms max.		ON to OFF: 10 ms max. OFF to ON: 40 ms max.
Startup waiting time			1 s max.		
Ambient light intensity			Incandescent lamp: 3,000 lx max. (light intensity on the receiver surface) Sunlight: 10,000 lx max. (light intensity on the receiver surface)		
Ambient temperature			During operation: -10 to 55°C, During storage: -30 to 70°C (with no freezing or condensation)		
Ambient humidity			During operation: 35 to 95% RH, During storage: 35 to 95% RH (with no condensation)		
Insulation resistance			20 MΩ min. (at 500 VDC)		
Dielectric strength voltage			1000 VAC 50/60 Hz 1 min.		
Vibration resistance (Destruction)			10 to 55 Hz, double amplitude 0.7 mm, X, Y and Z directions 20 sweeps		
Shock resistance (Destruction)			100 m/s ² , X,Y and Z directions 1000 times		
Degree of protection			IP65 (IEC60529)		
Connection method			M12 connector, 8 pins		
Weight (packaged)			Calculate with the following equation: Weight of light curtain with protective height of 180 mm to 738 mm (g) = (Protective height + 100) × 2 + 1300 Weight of light curtain with protective height of 747 mm to 1402 mm (g) = (Protective height + 100) × 2 + 1700 Weight of light curtain with protective height of 1417 mm to 1822 mm (g) = (Protective height + 100) × 2 + 2100		
Materials			Case: Aluminum, Cap: Zinc die-cast, Optical cover: PMMA (acrylic resin), Cable: Oil-proof PVC		
Accessories			Test rod *5, Instruction manual, Error mode label, Mounting brackets (top and bottom), Mounting brackets (intermediate) *6		
Applicable standard			IEC61496-1, EN61496-1 Type 4 ESPE (Electro-Sensitive Protective Equipment) IEC61496-2 Type 4 AOPD (Active Opto-electronic Protective Devices)		

*1. The 4 digits in □□□□ in the model number represent the protective height. Use the formula given in the information on protective height specifications to calculate the height. For example, if the beam gap is 9 mm, and the No. of beams is 21, the protective height will be 9 × 21 = 189 mm. The model with this protective height is F3SN-A0189P14.

*2. Available for the F3SN-A□□□□P□□-01

*3. For the factory setting, the manual reset mode is set to the "start/restart" interlock. Using the F39-MC11 can select either the start interlock or the restart interlock.

*4. For the factory setting, the function is not set. It can be enabled with the F39-MC11.

*5. Provided with the F3SN only.

*6. The intermediate mounting bracket is supplied with the following types:
Types which have the total length of the light curtain from 640 mm to 1280 mm: 1 set for each of emitter and receiver
Types which have the total length of the light curtain over 1280 mm: 2 sets for each of emitter and receiver

*7. These models are customized at our factories.

■ Ratings and Performance

◆ Accessories

● Control unit

Item	Type	F3SP-B1P
Applicable Sensor		F3SN-A, F3SH-A
Supply voltage		24 VDC ±10%
Power consumption		1.7 WDC max. (does not include the Sensor's current consumption)
Operating time		100 ms max. (does not include the Sensor's response time)
Response time		10 ms max. (does not include the Sensor's response time)
Relay output	No. of connection	3a + 1b
	Rated load	25 VAC 5A (cos diameter = 1), 30 VDC 5A L/R = 0ms
	Rated carry voltage	5 A
	Maximum switching voltage	25 VAC, 60 VAC
Connection method	Between Sensors	M12 connector (8 pins)
	Other	Terminal block
Weight (packaged)		280 g
Accessories		Instruction manual

● Setting console

Item	Type	F39-MC11
Applicable Sensor		F3SN-A, F3SH-A
Supply voltage		24 VDC ±10% (provided from the Sensor)
Connection method		Cable (Included)
Weight (packaged)		360 g
Accessories		One branching connector, One connector cap, 2-m cable, Instruction manual

For details on the setting console, refer to the instruction manual provided with the product.

● External indicator

Item	Type	F39-A01PR-L (for Emitter) F39-A01PR-D (for Receiver)	F39-A01PG-L (for Emitter) F39-A01PG-D (for Receiver)
	Applicable Sensor		F3SN-A□□□□P□□-01 F3SH-A09P03-01
Light source		Red LED	Green LED
Supply voltage		24 VDC ±10% (provided from the Sensor)	
Current consumption		40 mA max. (provided from the Sensor)	
Connection method		M12 connector	
Weight (packaged)		80 g	

■ Safety-related Function

● Interlock function

The auto reset mode and the manual reset mode are wire selectable features of the F3SN-A/F3SH-A.

Auto reset mode

After the power is turned ON and none of the beams are interrupted the OSSD (Output Signal Switching Device) outputs will go to their ON-state.

Manual reset mode

For the factory setting, the start/restart interlock is selected in the manual reset mode. When the light curtain enters the interlock condition, it keeps the OSSD outputs in the OFF-state. Even if all beams become free, the OSSD outputs will not go to the ON-state. When none of the beams are interrupted in the detection zone, applying the reset input (*) resets the interlock condition and the OSSD outputs go to the ON-state.

* Apply a voltage of 24 VDC (9 VDC to Vs, nominal 24 VDC) to the reset input line for 100 ms or more, then remove power to the reset input line or apply a voltage of 0 VDC.

• Start/restart interlock

After the power is turned ON, or when at least one beam is interrupted, the light curtain enters the interlock condition.

• Start interlock

Only after power ON, the light curtain enters the interlock condition.

• Restart interlock

Only when at least one beam is interrupted, the light curtain enters the interlock condition.

● Fixed blanking function (F3SN-A only)

This function is set with the F39-MC11 setting console and disables part of detection zone of the light curtain. If an object enters the disabled detection zone, the OSSD outputs status will not change. This function is used when there is a stationary object in the detection zone that needs to be ignored.

● Floating blanking function (F3SN-A only)

This function is set with the F39-MC11 setting console. During normal operation when floating blanking is disabled, and at least one beam is interrupted the light curtain will go to the OFF-state. However, using this function prevents the light curtain from going to the OFF-state until multiple beams (*1, 2, 3) are interrupted.

*1. The number of the floating blanking beams can be selected in the range of 2 to 4 beams.

*2. This function can be set to be active only if the interrupted beams are adjacent to each other.

*3. This function can be set so that the top and bottom beams cannot be set for the function.

■ Diagnostic Functions

● Self-test

After power ON, the F3SN-A/F3SH-A performs a complete self-test within 1 second. In addition, it performs a self-test (within response time) periodically during operation.

● External test

This function stops the emission of light from the Sensor using an external signal and checks that the Sensor operates properly.

● Lockout condition

If an error is detected by the self-test the light curtain enters the lockout condition, keeps the OSSD outputs in their OFF-state and displays the error mode. Turning the power ON again, lockout condition can be cleared either by resetting the power or by changing the setting of the reset switch from closed to open (open to closed for auto-reset). (With some errors, the lockout condition is automatically reset when the Sensor confirms that the cause of the error has been removed.)

● EDM (External device monitoring)

This function makes it possible to monitor the state of the NC contacts of the MPCEs, so that a malfunction of a MPCE, such as a welded contact, can be detected. Connect the NC contact of the MPCEs to the EDM input line of the receiver. If the correct logical relationship between the OSSD outputs and the EDM input is not kept, the light curtain immediately enters the lockout condition and the OSSD outputs will go to their OFF-state. The light curtain's normal operation is up to 300 ms max.^(*), this allows for the delay time caused by the release of the MPCEs. To ensure the correct usage of this function, the MPCEs must be safety-approved types with forcibly-guided contacts.

When the EDM is not used

In the case the EDM input is not used, connect the auxiliary output in the Dark-ON output mode to the EDM input line, or disable the EDM with the F39-MC11 setting console.

* The value can be changed by the F39-MC11.

■ Non-safety Output

● Auxiliary output

The default of this output is the reverse signal of the safety outputs (Dark-ON output). This output can be used for monitoring purposes by connecting it to a device such as a PLC.

The auxiliary output can be selected to give one of the following output operation modes by the F39-MC11.

- Dark-ON output mode
- Light-ON output mode
- Light diagnosis mode
- Lockout mode
- Outermost-beam monitoring mode
- Specified-beam mode
- Blanking monitoring mode (F3SN-A only)

● External indicator output

(F3SN-A□□□□P□□-01, F3SH-A09P03-01 only)

This output can be connected to an external indicator to display one of the operation modes as selected by the F39-MC11. The default of this output is Light-ON output.

■ Beam Center-line

The beam center-line is the line going through all of the beams. (See diagram on right.)

This position is a reference line for measuring safety distance. Use the line closer to the hazardous area as a reference line for the safety distance.

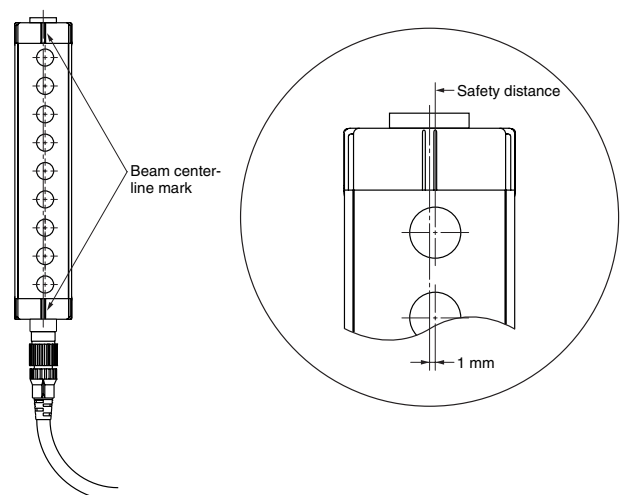

F3SN-A/F3SH-A Safety Light Curtain/Multi-beam Safety Sensor

Wiring Diagram

Wiring for the Manual reset mode and the EDM function

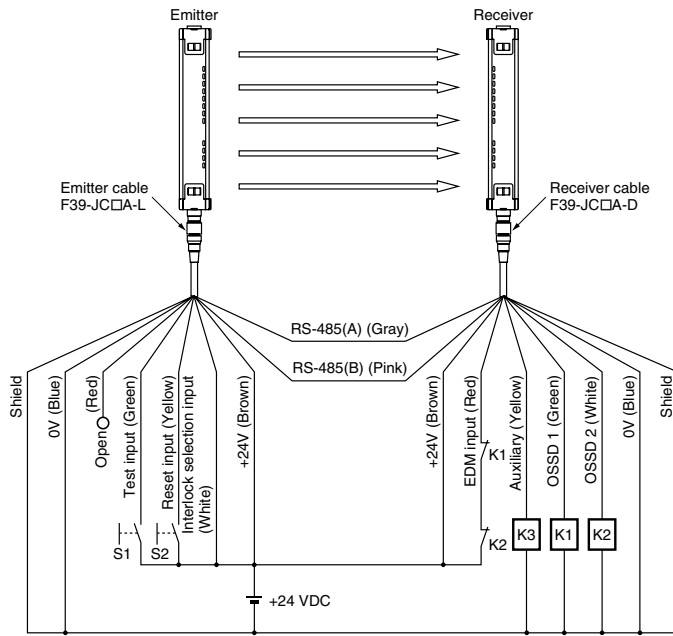

Wiring for the Auto reset mode

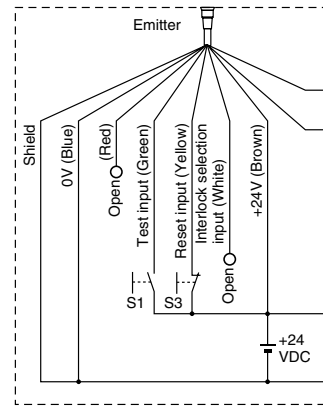

- S1: External test switch
- S2: Interlock/Lockout reset switch
- S3: Lockout reset switch (If the switch is not necessary, connect between the reset input and +24VDC.)
- K1, K2: Relay that control the dangerous zone, etc.
- K3: Load, PLC, etc. (Used for monitoring)

Note: When the EDM is not necessary

- 1) If the auxiliary output is in the "Dark-ON output mode", only connect the auxiliary output to the EDM input.
- 2) Use the F39-MC11 to disable the EDM.

Combination with the F3SP-B1P

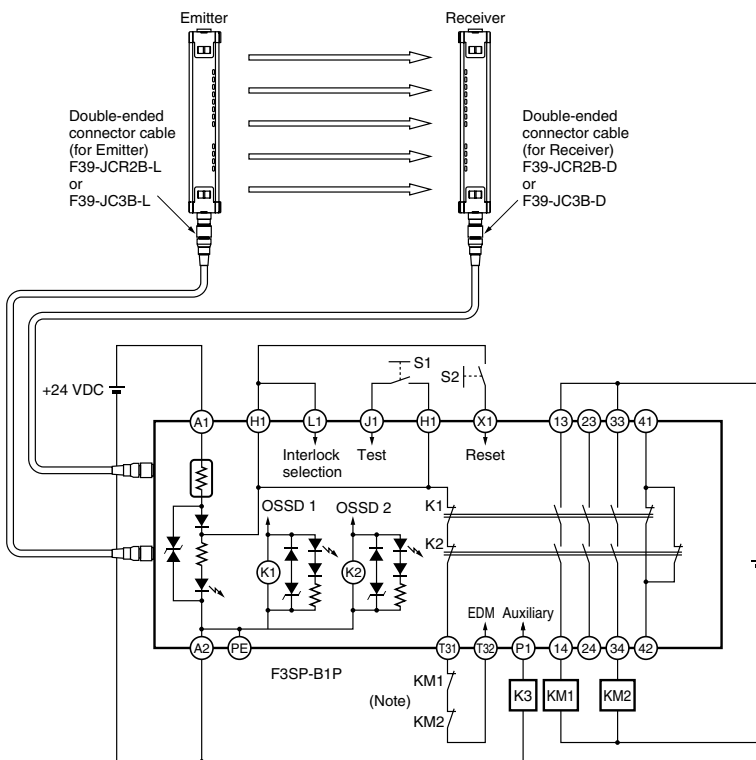

Wiring for the Auto reset mode

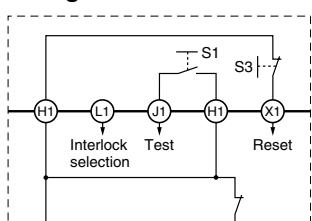

- S1: External test switch
- S2: Interlock/Lockout reset switch
- KM1, KM2: Relay that control the dangerous zone, etc.
- K3: Load, PLC, etc. (Used for monitoring)

Note: If the EDM is not necessary, short-circuit T31 and T32.

- S3: Lockout reset switch (If the switch is not necessary, connect between X1 and H1.)

Series connection (Up to 3 sets)

Light curtains can be connected in series using the types supplied with the connector for the series connection as shown in the figure below. Both the stand-alone type and the series connection type can be used for the light curtains located at the top end.

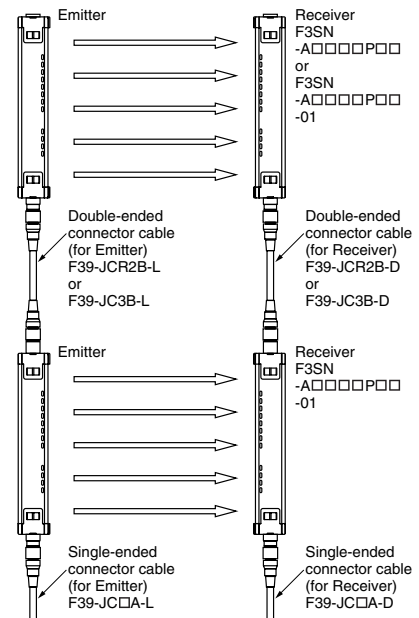

Note 1: In order to maintain performance characteristics, use the F39-JCR2B or the F39-JC3B to connect Sensors in series connection. The F39-JC7B, F39-JC10B, or F39-JC15B cannot be connected in series.

Note 2: The F3SN and F3SH cannot be connected in series.

I/O Circuit

Circuit

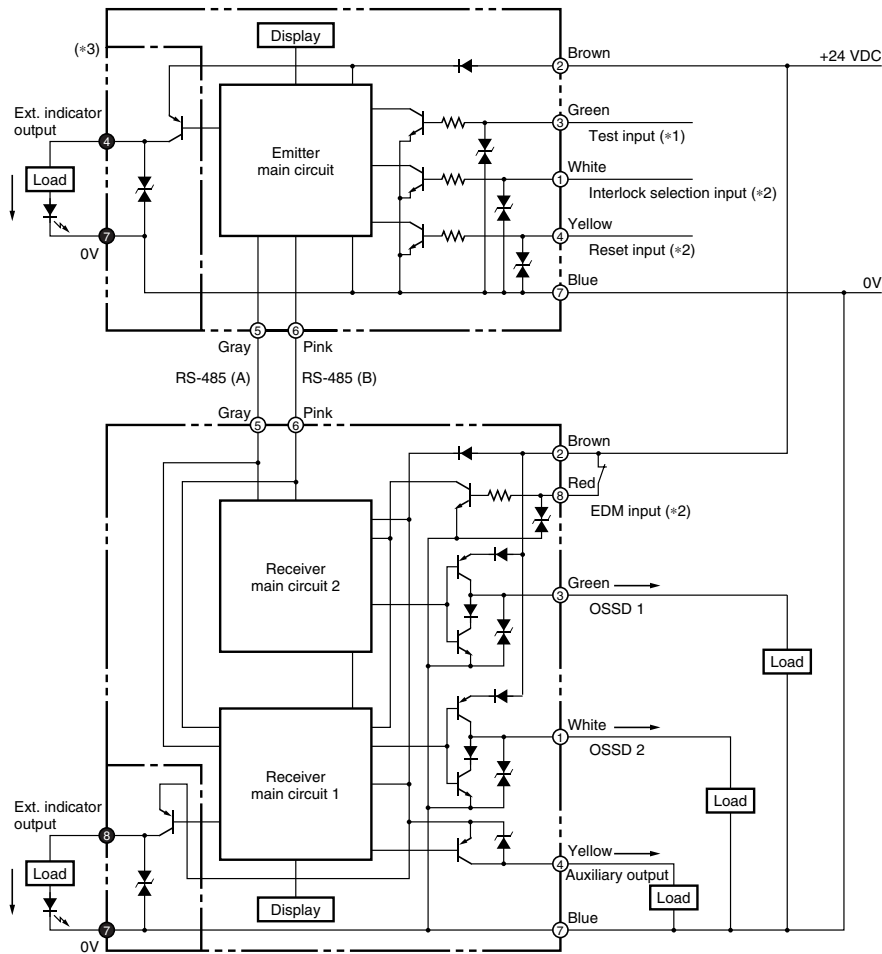

Connector Pins Arrangement

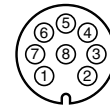

- *1. Open: normal light emission, Short to the +24 VDC: stops light emission
- *2. Refer to "Wiring for the Manual reset mode and the EDM function" or "Wiring for the Auto reset mode" on **page 8**.
- *3. The section encircled with the dashed line is applied for F3SN-A□□□□P□□-01 only.

Note: The numbers in ○ indicate pin numbers of the connectors.
The numbers in ● indicate pin numbers of the series connection connectors.

Single-ended connector cable

Type	Internal wiring	Pin No.	Wire color	Signal name	
				Receiver	Emitter
F39-JC3A (3m) F39-JC7A (7m) F39-JC10A (10m) F39-JC15A (15m)		1	White	OSSD 2	Interlock selection input
		2	Brown	+24 VDC	+24 VDC
		3	Green	OSSD 1	Test input
		4	Yellow	Auxiliary output	Reset input
		5	Gray	RS-485 (A)	RS-485 (A)
		6	Pink	RS-485 (B)	RS-485 (B)
		7	Blue	0 V	0 V
		8	Red	EDM input	N.C.

F3SN-A/F3SH-A Safety Light Curtain/Multi-beam Safety Sensor

I/O Circuit

Output waveform of the OSSD outputs

The OSSD outputs will be OFF as shown in the following figure in order to perform the OSSD circuit self-test when the light curtain is in the ON-state. The OSSD circuit diagnosis is correct when this OFF signal is fed back. If the output signal does not contain an OFF signal, the receiver determines that there is an output circuit or wiring failure and goes into the lockout condition. The number of OFF signals depends on the number of light curtains connected in series.

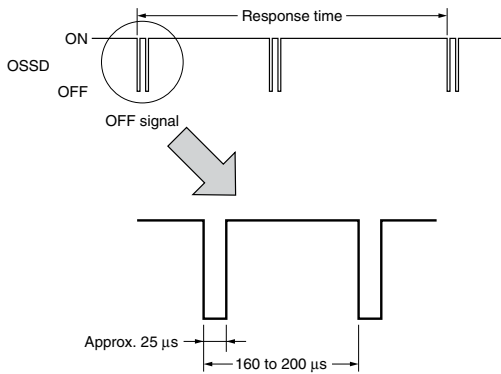

No. of light curtains connected in series	No. of OFF signals within the response time
No series connection	1
2 light curtains	2
3 light curtains	3

Note: This chart indicates the instance of 2 light curtains series connection.

In the same way, the OSSD outputs will be ON as shown in the following figure, to perform the OSSD circuit self-test when the light curtain is in the OFF-state. Check the input response time of a machine connected to the F3SN-A carefully to ensure the machine will not malfunction due to the OFF signal.

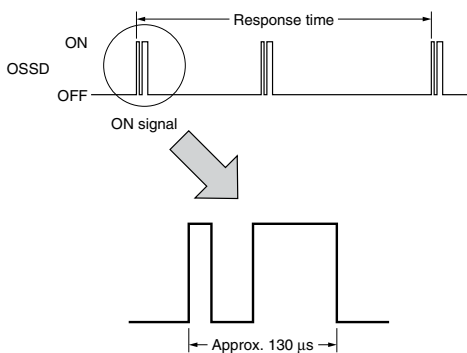

No. of light curtains connected in series	No. of ON signals within the response time
No series connection	1
2 light curtains	2
3 light curtains	3

Engineering Data (Typical Examples)

Parallel operating range F3SN-A1107P14

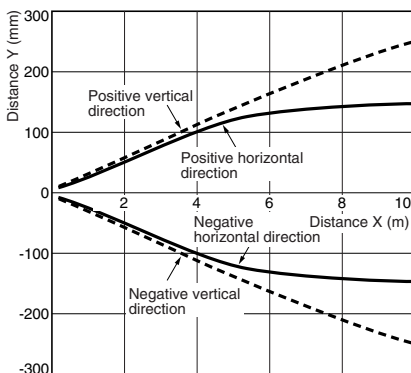

Horizontal direction Vertical direction

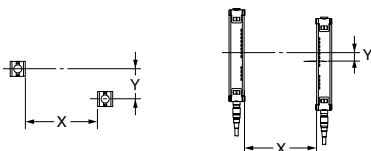

Angular range (Angle of elevation) F3SN-A1107P14

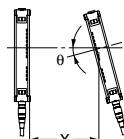
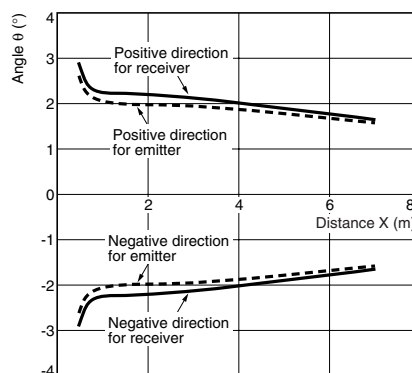

Angular range (Angle of rotation) F3SN-A1107P14

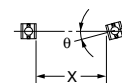
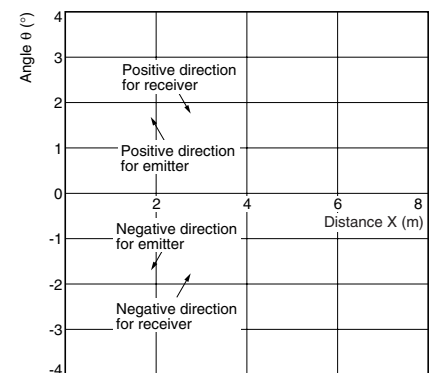

■ Correct Usage

This catalog is intended as a guide for product selection.

Be sure to use the instruction manual provided with the product for actual operation.

● Regulations and standards

1. The F3SN-A/F3SH-A has not received the type approval provided by Article 44-2 of the Industrial Safety and Health Law of Japan. Therefore, it cannot be used in Japan as a safety device for pressing or shearing machines provided by article 42 of that law.
2. (1) The F3SN-A/F3SH-A is electro-sensitive protective equipment (ESPE) in accordance with European Union (EU) Machinery Directive Annex IV, B, Safety Components, Item 1.
 (2) The F3SN-A/F3SH-A complies with the following regulations and standards:
 1. EU regulations
 Machinery Directive: Directive 98/37/EC
 EMC Directive: Directive 89/336/EEC
 2. European standard: EN61496-1 (TYPE 4 ESPE)
 3. International standard: IEC61496-1 (TYPE 4 ESPE), IEC61496-2 (TYPE 4 AOPD)
- (3) The F3SN-A/F3SH-A received the following approvals from the EU accredited body DEMKO A/S:
 - EC Type-Examination in accordance with the EU Machinery Directive
 - Certificate of a Competent Body for EMC
- (4) The F3SN-A/F3SH-A received the following approvals from the Third Party Assessment Body UL:
 - Certificate of UL listing for US and Canadian safety standards
 Both of which are: TYPE 4 ESPE (IEC61496-1)
 TYPE 4 AOPD (IEC61496-2)
 - Certificate of Programmable System (UL1998, IEC61496-1)

⚠ WARNING

● Detection zone and intrusion path

Safety Light Curtain F3SN-A

Install protective structures around the machine so that you must pass through the detection zone of the F3SN-A to reach a hazardous part of the machine. Install the F3SN-A so that some part of the operator's body remains in the detection zone at all times when the operator works in a hazardous area.



Correct Installation

A hazardous part of a machine can be reached only by passing through the sensor detection zone.

Some part of the operator's body remains in the detection zone while they are working.

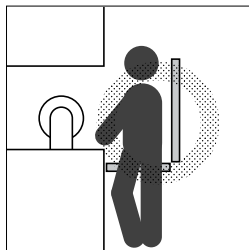
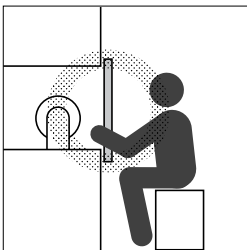

Incorrect Installation

A hazardous part of a machine can be reached without passing through the sensor detection zone.

A worker is between the sensor detection zone and a hazardous part of a machine.

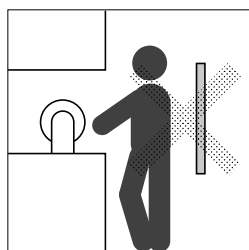
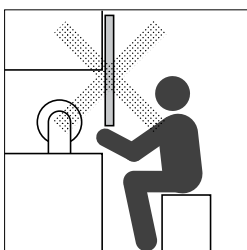

Multi-beam Safety Sensor F3SH-A

Install protective structures around the machine so that you must pass through the detection zone of the F3SH-A to reach a hazardous part of the machine.



If it is possible for an operator to get between the Sensor's detection zone and the hazardous part of the machine, design the system so that machinery cannot start up automatically. Also, in order that machinery cannot restart while the operator is in the hazardous area, position the switch for restarting machinery in a location from which the status of the hazardous area can be seen clearly, and where it cannot be operated from within the hazardous area.

Failure to do so may result in serious injury.

Use of the fixed blanking function (F3SN-A only)

After setting the fixed blanking, check that the F3SN-A detects a test rod at any position in the detection zone through which a person can reach the hazardous part of the machine. If any positions are found by check above, install protective structures to prevent intrusion, which the F3SN-A can not detect.



Failure to do so may result in serious injury.

■ Correct Usage

⚠ WARNING

● Safety distance

Always maintain a safe distance (S) between the Sensor and a hazardous part of a machine.

Serious injury may result if the machine does not stop before someone reaches the hazardous part.



Use of the floating blanking increases the size of the detection capability. To calculate a safety distance, be sure to use the increased size of the detection capability. Failure to do so causes the machine to fail to stop before an operator reaches the dangerous area and may result in serious injury.



The "Safety distance" is the minimum distance that must be maintained between the F3SN-A/F3SH-A and a hazardous part of a machine in order to stop the machine before someone or something reaches it. The safety distance is calculated based on the following equation when a person moves perpendicular to the detection zone of a light curtain.

Safety distance (S) = Intrusion speed into the detection zone (K) × Total response time for the machine and light curtain (T) + Additional distance calculated based on the detection capability of the light curtain (C)(1)

The safety distance varies with national standards and individual machine standards. Be sure to refer to related standards.

The equation is also different if the direction of intrusion is not perpendicular to the detection zone of the light curtain.

<Reference> Method for calculating safety distance as provided by European Norm EN999 (for intrusion perpendicular to the detection zone)

Safety Light Curtain F3SN-A

[Detection capability: 40mm or less]

Substitute K = 2,000 mm/s and C = 8 (d – 14 mm) in equation (1) and calculate as shown below.

$$S = 2,000 \text{ mm/s} \times (T_m + T_s) + 8 (d - 14 \text{ mm}) \dots\dots(2)$$

Where: S = Safety distance (mm)

T_m = Machine response time (s) *1

T_s = Light curtain response time (s) *2

d = Detection capability of the light curtain (mm)

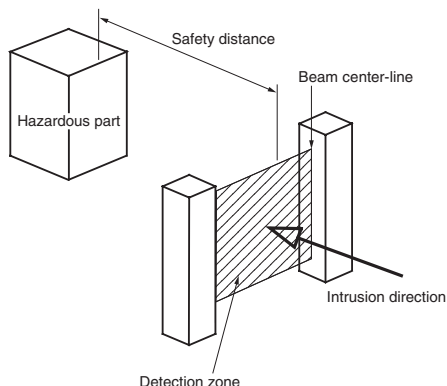

e.g.:

$$T_m = 0.05 \text{ s}, T_s = 0.01 \text{ s}, d = 14 \text{ mm}:$$

$$S = 2,000 \text{ mm/s} \times (0.05 \text{ s} + 0.01 \text{ s}) + 8 (14 \text{ mm} - 14 \text{ mm}) = 120 \text{ mm}$$

Use S = 100 mm if the result of equation (2) is less than 100 mm.

Recalculate using the following equation with K = 1,600 mm/s if the result is over 500 mm.

$$S = 1,600 \text{ mm/s} \times (T_m + T_s) + 8 (d - 14 \text{ mm}) \dots\dots(3)$$

Use S = 500 mm if the result from equation (3) is less than 500 mm.

<Reference> Method for calculating the safety distance as provided by ANSI B11.19 (US)

Safety distance (S) = Intrusion speed into the detection zone (K) × Response time (T_s + T_c + T_r + T_{bm}) + Additional distance (D_{pf})(5)

Where: K = Intrusion speed (Recommended value in OSHA standards is 1,600 mm/s)

ANSI B11.19. does not define Intrusion speed (K). When determining K, consider possible factors including physical ability of operators.

T_s = Time required for machine to stop (s)

T_r = F3SN-A response time (s) *

T_c = Maximum response time required for machine control circuit to apply brake (s)

T_{bm} = Additional time (s)

If the machine is provided with a brake monitor, T_{bm} = brake monitor setting time – (T_s + T_c). If not provided with a brake monitor, it is recommended to determine a value more than 20% of (T_s + T_c) as the additional time.

D_{pf} = Additional distance. D_{pf} is calculated as follows based on ANSI standards.

D_{pf} = 3.4 × (d – 7.0): d is the detection capability of the light curtain (mm).

e.g.:

Where: K = 1,600 mm/s, T_s + T_c = 0.06 s,

Brake monitor setting time = 0.1 s, T_r = 0.1 s,

d = 14 mm,

From equation (5):

$$T_{bm} = 0.1 - 0.06 = 0.04 \text{ s}$$

$$D_{pf} = 3.4 \times (14 - 7.0) = 23.8 \text{ mm}$$

$$S = 1,600 \times (0.06 + 0.1 - 0.04) + 23.8 = 215.8 \text{ mm}$$

* The light curtain response time refers to the time required for output to change from ON to OFF.

Multi-beam Safety Sensor F3SH-A

[Detection capability: over 40mm]

Substitute K = 1,600 mm/s and C = 850 mm in equation (1) and calculate as shown below.

$$S = 1,600 \text{ mm/s} \times (T_m + T_s) + 850 \dots\dots(4)$$

Where: S = Safety distance (mm)

T_m = Machine response time (s) *1

T_s = Light curtain response time (s) *2

e.g.:

$$T_m = 0.05 \text{ s}, T_s = 0.01 \text{ s}:$$

$$S = 1,600 \text{ mm/s} \times (0.05 \text{ s} + 0.01 \text{ s}) + 850 \text{ mm} = 946 \text{ mm}$$

*1. The machine response time refers to the maximum time from the moment the machine receives a stop signal to the moment the hazardous part of the machine stops. The machine response time should be measured on actual machines. The machine response time should be measured and confirmed periodically.

*2. The light curtain response time refers to the time required for output to change from ON to OFF. When using a Controller, add the response time for the Controller to the response time for the Sensor (see above) when calculating the safe distance.

Correct Usage

⚠ WARNING

Distances from reflective surfaces

Be sure to install the F3SN-A/F3SH-A to minimize the effects of reflection from nearby surfaces.

Failure to do so may cause detection to fail and may result in serious injury.



Side View

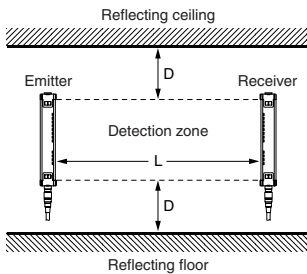

Top View

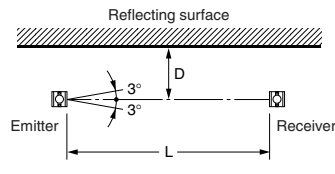

Install the F3SN-A/F3SH-A with minimum Distance D shown above from reflective surfaces (highly reflective surfaces) such as metal walls, floors, ceilings, and work pieces.

Distance between emitter and receiver (Operating range L)	Minimum installation distance D
0.2 to 3 m	0.16 m
over 3 m	$L \times \tan 3^\circ = L \times 0.052$ (m)

Correct Use

Installation

How to prevent mutual interference

When installing two or more light curtains, the installation may cause mutual interference. The diagrams below show installations that may cause mutual interference. To prevent this, either connect the Sensors in series connection, or install so that the receivers will be exposed to no light other than the light emitted by their partner emitters.

Installation which may cause mutual interference

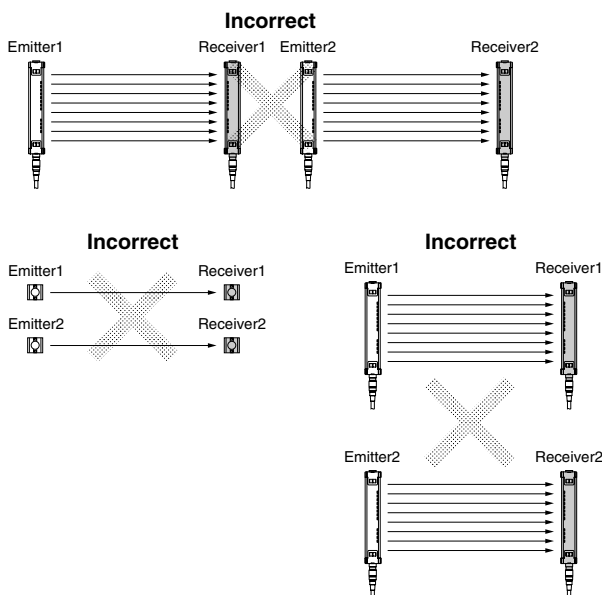

Installation to prevent mutual interference

- Install so that the two light curtains emit in the opposite directions (staggered).

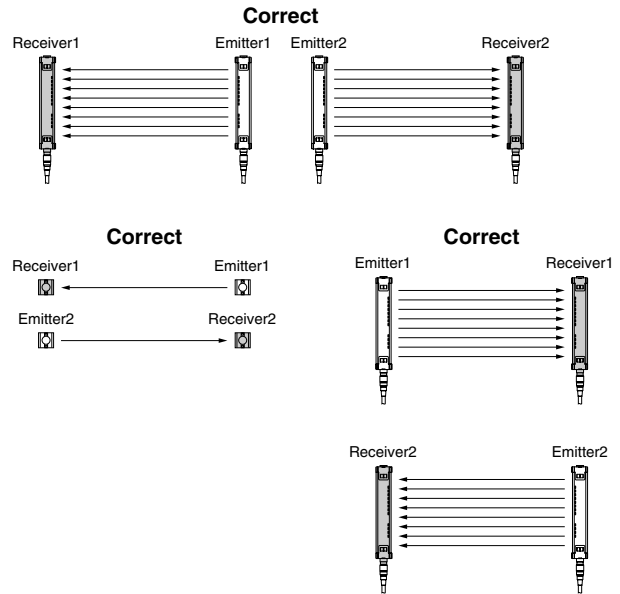

- Install a light interrupting wall in between sensors.

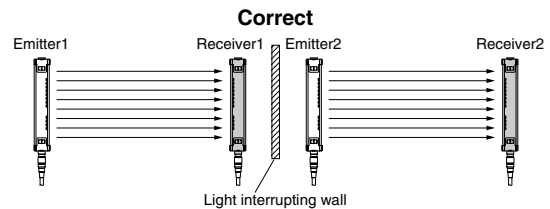

- Install the light curtains facing away from the one another to eliminate mutual interference.

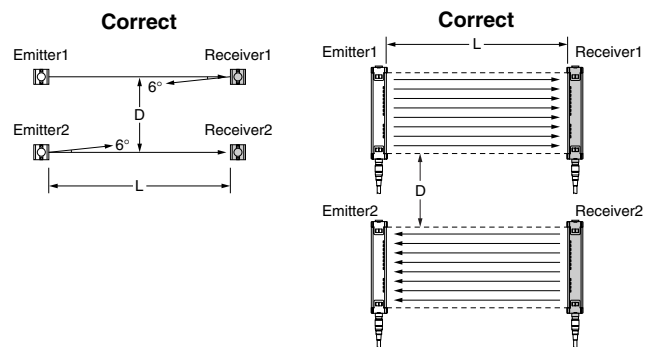

Distance between emitter and receiver (Operating range L)	Minimum installation distance D
0.2 to 3 m	0.32 m
over 3 m	$L \times \tan 6^\circ = L \times 0.105$ (m)

Operating range

If the distance between the emitter and the receiver is less than 0.2 m, there is a possibility of chattering. Be sure to use the Sensor within the rated operating range.

F3SN-A/F3SH-A Safety Light Curtain/Multi-beam Safety Sensor

Correct Usage

Correct Use

Names and Functions of Parts

Emitter (F3SN-A, F3SH-A)

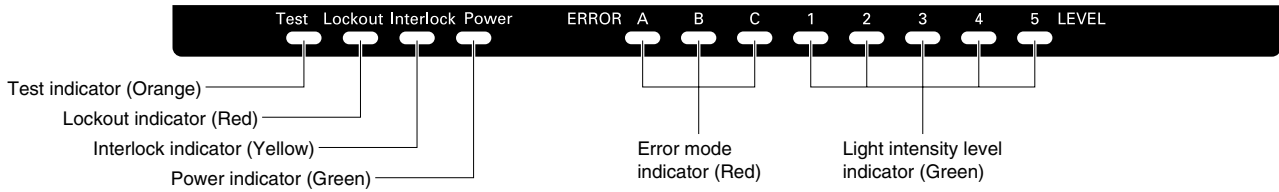

Receiver (F3SN-A)

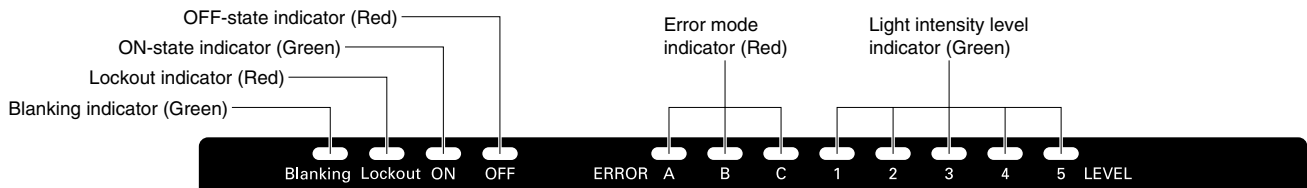

Receiver (F3SH-A)

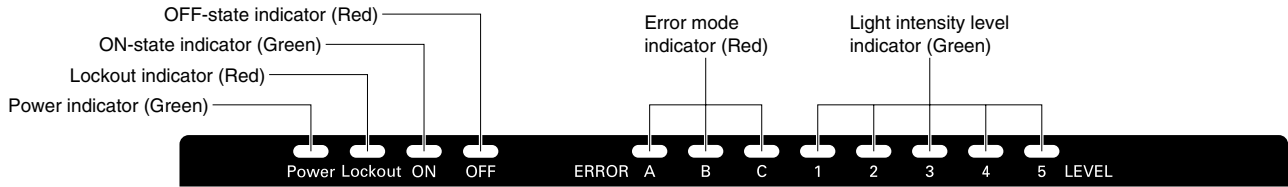

Power indicator	Lit when power is supplied (Always lit).....F3SN-A, F3SH-A Emitter Lit when power is supplied, flashing when the F39-MC11 is connected.....F3SH-A Receiver (See note)
Interlock indicator	Lit during interlock condition
Lockout indicator	Flashing during lockout condition
Test indicator	Lit during external test (See note)
ON-state indicator	Lit when OSSD outputs are in ON-state
OFF-state indicator	Lit when OSSD outputs are in OFF-state
Blanking indicator	Lit when blanking is set, flashing when the F39-MC11 is connected (See note)

Note: As a preventive maintenance feature, these indicators will flash after a lapse of 30,000 hours.

	1	2	3	4	5	Light intensity level
Light intensity level indicator 						200% and above of ON threshold level
						150 to 200% of ON threshold level
						100 to 150% of ON threshold level
						75 to 100% of ON threshold level
						50 to 75% of ON threshold level
						less than 50% of ON threshold level

	A	B	C	Cause of error
Error mode indicator 				The Interlock selection input line or the reset input line is not wired correctly or became open.
				Relay contact is welded. Releasing time of the relay takes too long. The EDM input line is not wired correctly or became open.
				Communication line (RS-485) is not wired correctly, became open, or causes other errors.
				One of the OSSD outputs is shorted or is not wired correctly.
				Mutual interference. Interference light is received.
				Types of the receiver and emitter are not the same. Numbers of the receiver and emitter connected in series are not the same.
				External noise. Internal hardware failure of the receiver or the emitter.

■ Dimensional Drawings (Unit: mm)

◆ Specification

F3SN-A□□□□P□□
F3SN-A□□□□P□□-01

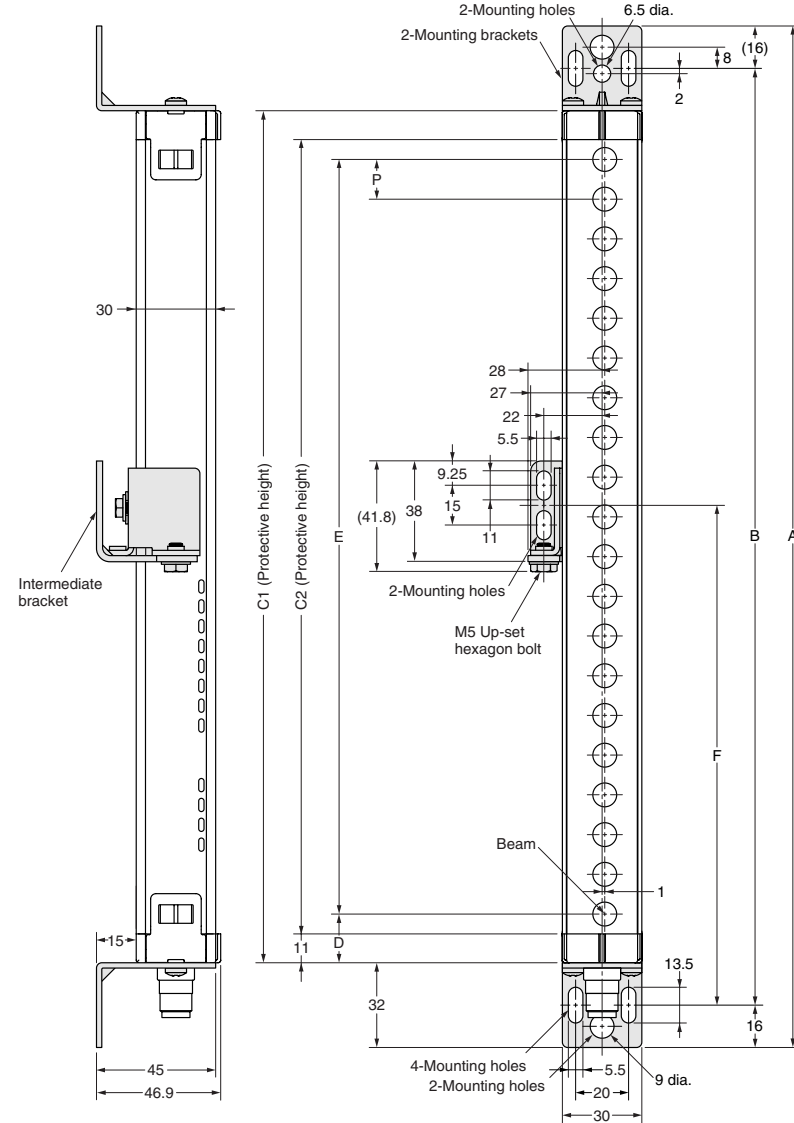
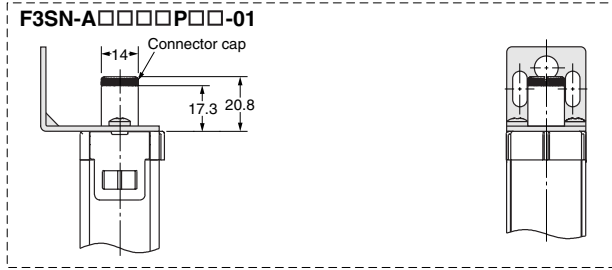

Mounting screw holes

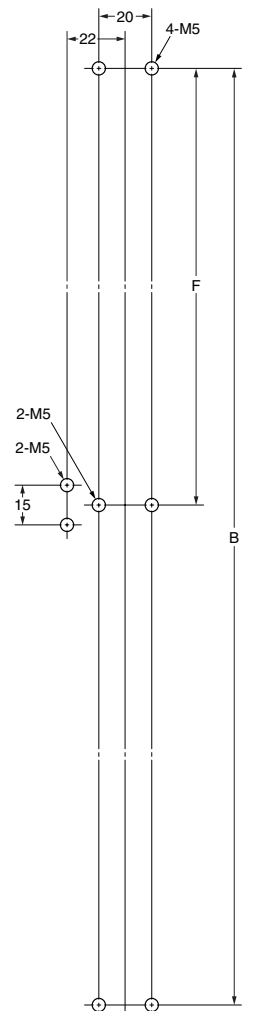

Dimensions according to the type can be calculated by using the following equations.

F3SN-A□□□□P14, F3SN-A□□□□P14-01
 Dimension C2 (Protective height): 4 digits in the type name
 Dimension A = C2 + 86
 Dimension B = C2 + 54
 Dimension D = 15.5
 Dimension E = C2 - 9
 Dimension F: See the below table.
 Dimension P = 9

Protective height (C2)	Number of intermediate mounting bracket	Dimension F (See note)
to 0620	0	—
0621 to 1125	1	F = B / 2

F3SN-A□□□□P25, F3SN-A□□□□P25-01
 Dimension C1 (Protective height): 4 digits in the type name
 Dimension A = C1 + 64
 Dimension B = C1 + 32
 Dimension D = 18.5
 Dimension E = C1 - 37
 Dimension F: See the below table.
 Dimension P = 15

Protective height (C1)	Number of intermediate mounting bracket	Dimension F (See note)
to 0640	0	—
0641 to 1280	1	F = B / 2
1281 to 1822	2	F = B / 3

Note: If value F obtained from the above equation is not used, set F to 670 mm or less.

F3SN-A/F3SH-A Safety Light Curtain/Multi-beam Safety Sensor

Dimensional Drawings (Unit: mm)

Specification

F3SH-A09P03
F3SH-A09P03-01

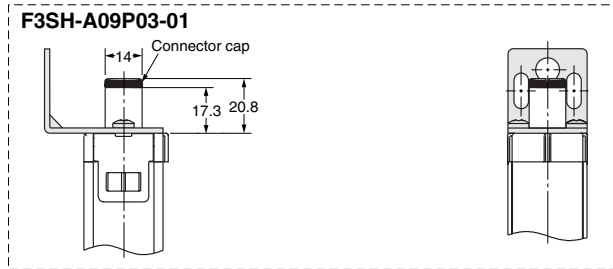

Mounting screw holes

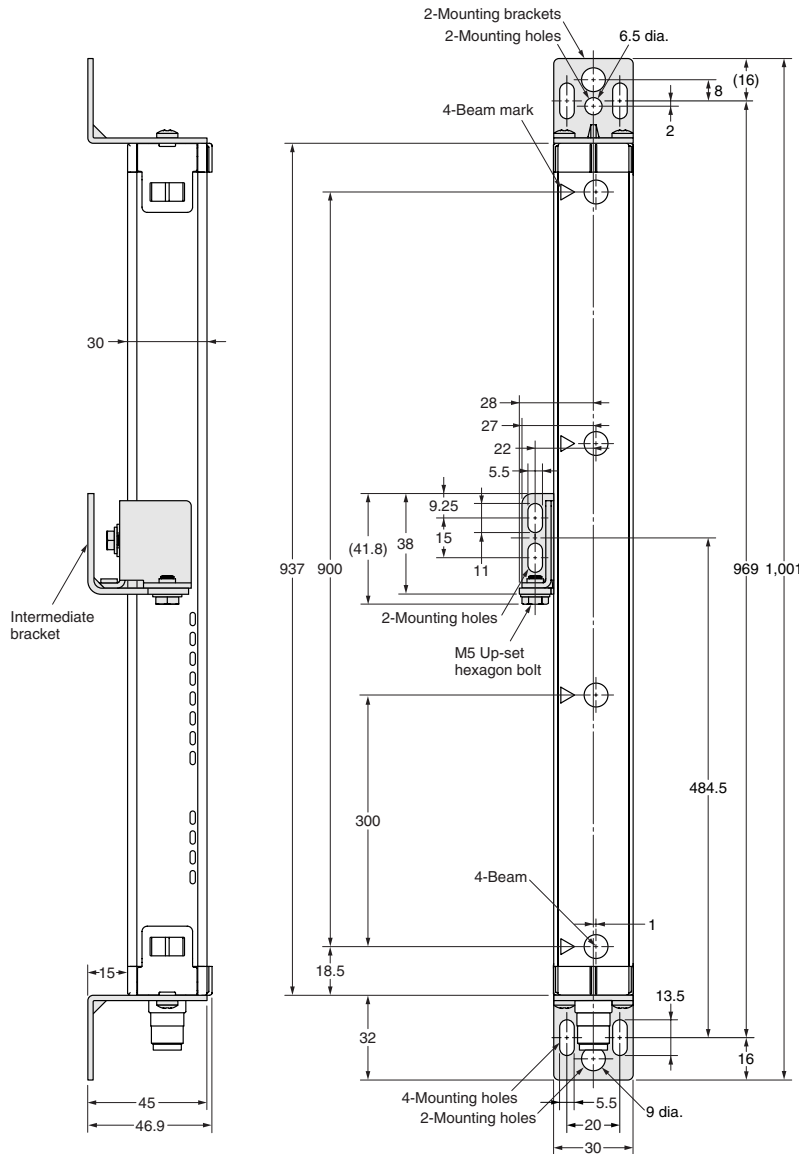
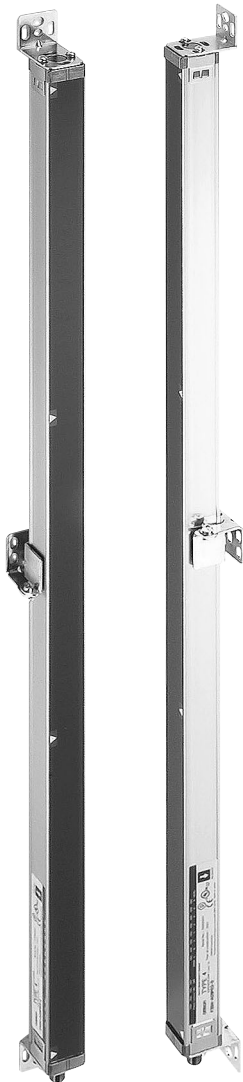
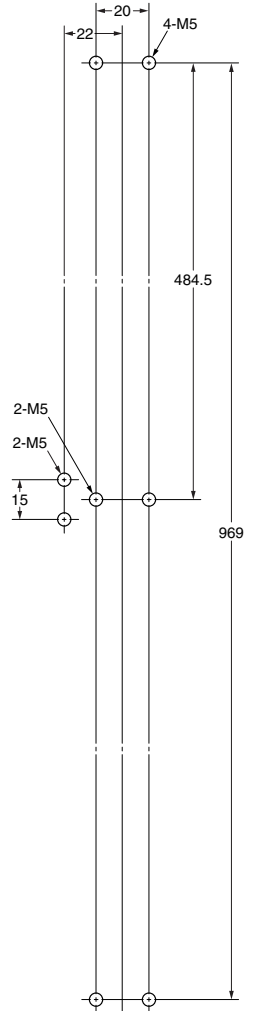

Mounting Precautions for the F3SN-A and F3SH-A

Note 1: The mounting bracket (3) (see ●Mounting brackets (Intermediate)) is shown on the left-hand side of the Sensor as an example. If the mounting bracket (3) is on the right-hand side of the Sensor then the mounting holes must also be on the right-hand side.

Note 2: When using with the cable bent, allow at least the dimensions shown on the right. (Minimum bending radius of cable: R36 mm.)

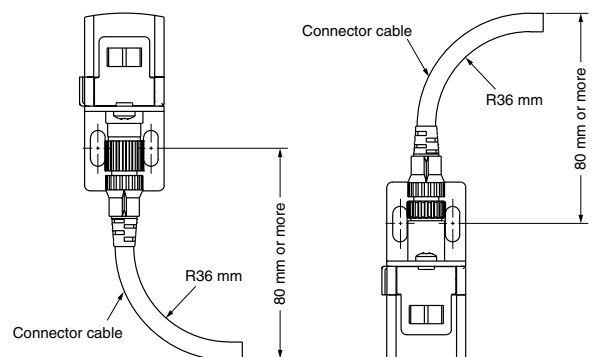

■ Dimensional Drawings (Unit: mm)

◆ Accessories

● Mounting bracket (top and bottom)

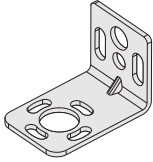

Material: Carbon steel

Provided with the product.

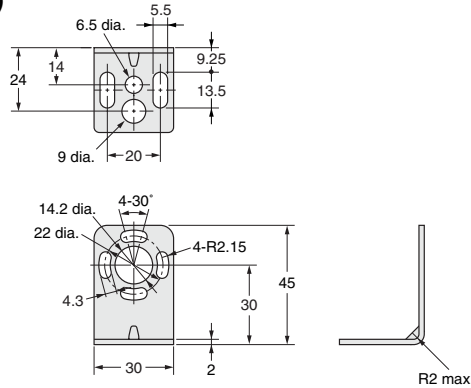

● Mounting bracket (intermediate)

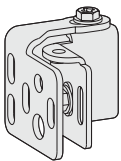

Material: Carbon steel

Provided with the product.

The number of brackets required depends on the total length of the Sensor.

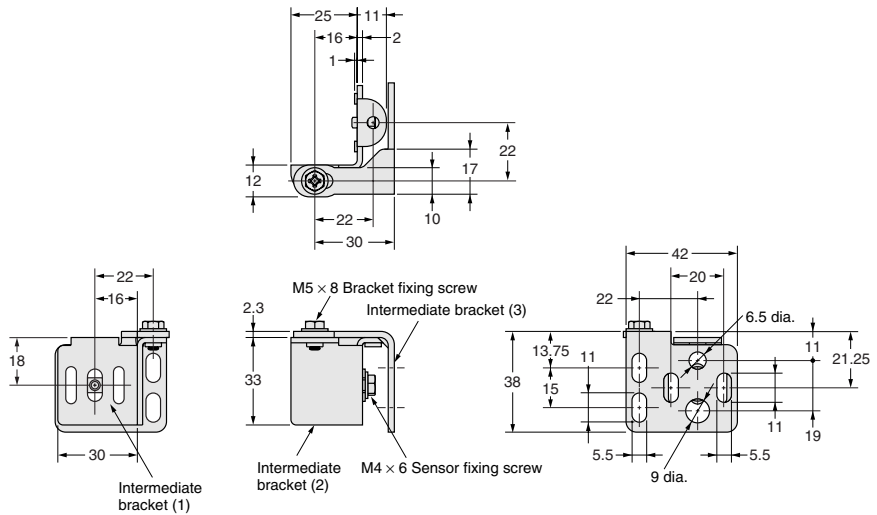

◆ Accessories (Optional)

● Single-ended connector cable

F39-JC3A (L = 3m) **F39-JC10A** (L = 10m)

F39-JC7A (L = 7m) **F39-JC15A** (L = 15m)

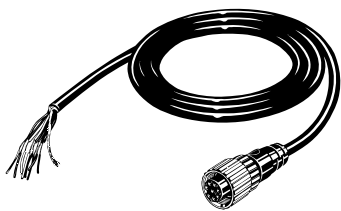

Color: Emitter (Gray)
Receiver (Black)

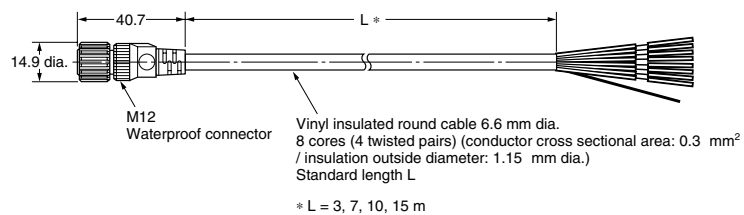

● Double-ended connector cable

F39-JCR2B (L = 0.2m) **F39-JC10B** (L = 10m)

F39-JC3B (L = 3m) **F39-JC15B** (L = 15m)

F39-JC7B (L = 7m)



Color: Emitter (Gray)
Receiver (Black)

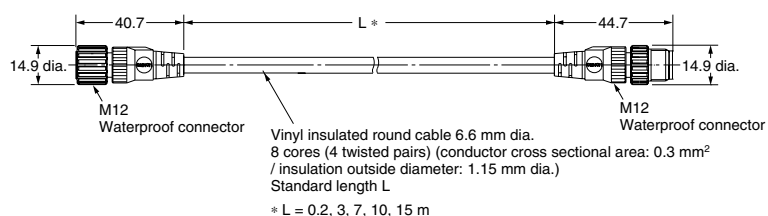

F3SN-A/F3SH-A Safety Light Curtain/Multi-beam Safety Sensor

Dimensional Drawings (Unit: mm)

Accessories (Optional)

Basic control unit F3SP-B1P

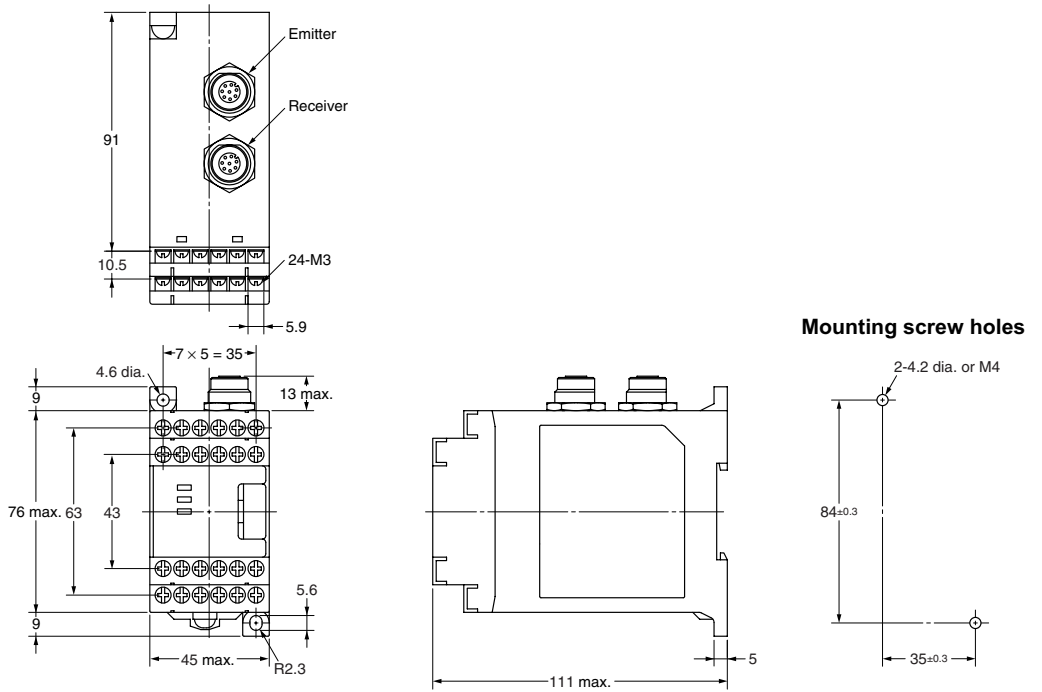

Setting console F39-MC11

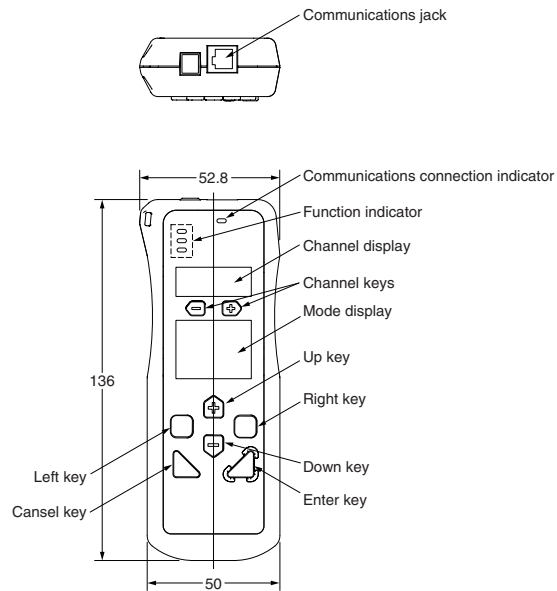

Branching connector (Supplied with F39-MC11)

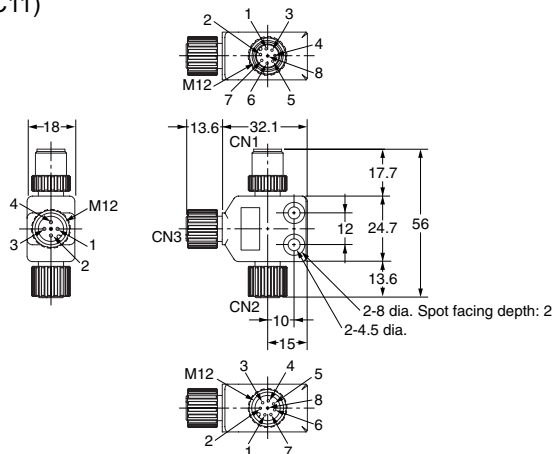

■ Dimensional Drawings (Unit: mm)

◆ Accessories (Optional)

● External indicator

F39-A01PR-L/-D

F39-A01PG-L/-D

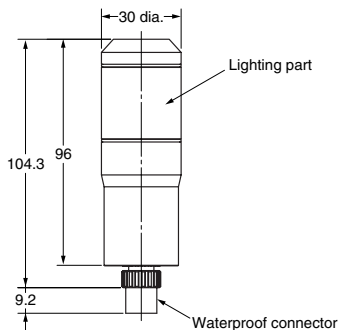

● Spatter protection cover

F39-HN□□□□-14

F39-HN□□□□-25

F39-HH09-03

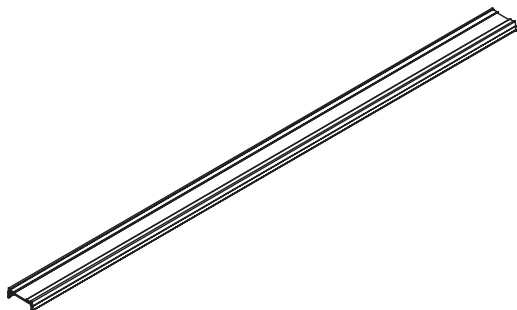

Protection cover

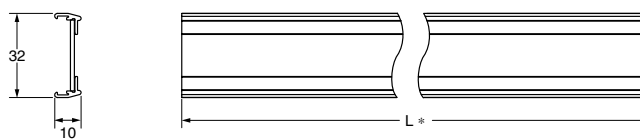

* L is as follows.

F39-HN□□□□-14	L = □□□□ mm
F39-HN□□□□-25	L = □□□□ - 22 mm
F39-HH09-03	L = 915 mm

Material: PC (Transparent area)
ABS (Non-transparent area)

Mounting dimension

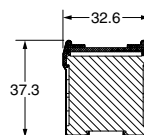

Fixing bracket

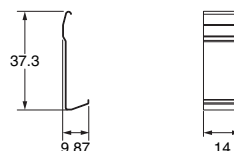

Material: SUS

Cat. No. E700-E2-01 In the interest of product improvement, specifications are subject to change without notice.

OMRON EUROPE B.V.

Wegalaan 67-69,
NL-2132 JD, Hoofddorf,
The Netherlands
Phone:+31 23 568 13 00
Fax:+31 23 568 13 88
www.eu.omron.com
