

Safety-door Hinge Switch

D4DH

- Polymer housing, IP65, and slow-action contacts with positive opening \ominus .
- Two actuator types are available:
 - Shaft
 - Arm lever
- Arm lever type can be adjusted to allow a right (180°), left (180°), or center (90° left or right) rotation.
- The head can be mounted in four directions.
- Double-insulation structure requires no grounding terminals. (with \square mark)
- 1- and 2-conduit models are available.
- Wide standard operating temperature range: -30°C to 70°C
- **Safety Standards:**
 - Conformity:
 - Machinery Directive
 - Low-voltage Directive
 - EN50047
 - EN1088



■ Approved Standard

- **Conformity:**
Machinery Directive, Low-voltage Directive, EN50047, EN1088
- **Approval:**

Agency	Standard	File No.
TÜV Rheinland	EN60947-5-1	R9650736
BIA	GS-ET-15	9610569
UL (see note)	UL508, CSA C22.2 No.14	E76675
SUVA	SUVA	6123Z

Note: CSA C22.2 No. 14 compliance was verified and approved by UL (Marked with UL).

Ordering Information

■ Model Number Legend

D4DH- \square \square \square

1 2 3

1. Conduit Size

- 1: Pg13.5 (1-conduit)
- 2: G¹/₂ (1-conduit)
- 3: 1/2-14NPT (1-conduit)
- 5: Pg13.5 (2-conduit)
- 6: G¹/₂ (2-conduit)

2. Built-in Switch

- 5: 1NC/1NO (Slow-action)
- A: 2NC (Slow-action)

3. Actuator

- AS: Shaft
- BC: Arm lever (mounted upward in the center position)

■ List of Models

Actuator	Conduit size		1NC/1NO (see note)	2NC (see note)
			Model	Model
Shaft	1-conduit	Pg13.5	D4DH-15AS	D4DH-1AAS
		G ^{1/2}	D4DH-25AS	D4DH-2AAS
		1/2-14NPT	D4DH-35AS	D4DH-3AAS
	2-conduit	Pg13.5	D4DH-55AS	D4DH-5AAS
		G ^{1/2}	D4DH-65AS	D4DH-6AAS
Arm lever	1-conduit	Pg13.5	D4DH-15BC	D4DH-1ABC
		G ^{1/2}	D4DH-25BC	D4DH-2ABC
		1/2-14NPT	D4DH-35BC	D4DH-3ABC
	2-conduit	Pg13.5	D4DH-55BC	D4DH-5ABC
		G ^{1/2}	D4DH-65BC	D4DH-6ABC

Note: All models have slow-action contacts with approved positive opening mechanisms on NC contacts only.

Specifications

■ Approved Standard Ratings

TÜV (EN60947-5-1)

Utilization category	AC-15
Rated operating current (I _e)	2 A
Rated operating voltage (U _e)	400 V

Note: Use a 10-A fuse type gI or gG as a short-circuit protective device that conforms to IEC269.

UL (UL508/CSA C22.2 No. 14)

A600

Rated voltage	Carry current	Current		Volt-amperes	
		Make	Break	Make	Break
120 VAC	10A	60 A	6 A	7,200 VA	720 VA
240 VAC		30 A	3 A		
480 VAC		15 A	1.5 A		
600 VAC		12 A	1.2 A		

■ Characteristics

Enclosure rating (see note 1)	IP65 (EN60947-5-1)	
Life expectancy (see note 2)	Mechanical: 1,000,000 times min. Electrical: 150,000 times min.	
Operating speed	2°/sec to 360°/sec	
Contact gap	2 x 2.0 mm min.	
Operating frequency	30 operations/minute max.	
Positive opening force (see note 3)	1 N • m min.	
Positive opening travel (see note 3)	45° min.	
Insulation resistance	100 MΩ min. (at 500 VDC) between terminals of same or different polarity and between each terminal and non-current-carrying metal part.	
Contact resistance	25 mΩ max. (initial value)	
Rated impulse voltage (U_{imp})	Between terminals of same polarity: U _{imp} 4 kV (EN60947-5-1) Between terminals of different polarity: U _{imp} 4 kV (EN60947-5-1) Between each terminal and non-current-carrying metal part: U _{imp} 4 kV (EN60947-5-1)	
Rated insulation voltage (U_i)	400 V (EN60947-5-1)	
Conditional short-circuit current	100 A (EN60947-5-1)	
Switching overvoltage	1,500 V max. (EN60947-5-1)	
Pollution degree (operating environment)	3 (EN60947-5-1)	
Conventional enclosed thermal current (I_{the})	10 A (EN60947-5-1)	
Protection against electric shock	Class II (double insulation)	
Vibration resistance	Malfunction: 10 to 55 Hz, 0.75 mm single amplitude	
Shock resistance	Mechanical: 1,000 m/s ² min. Malfunction: 300 m/s ² min.	
Ambient temperature	Operating: -30°C to 70°C (with no icing)	
Ambient humidity	Operating: 95% max.	
Weight	D4DH-15AS: Approx. 74 g D4DH-15BC: Approx. 84 g	
Material	Body and actuator flange	Glass-fiber reinforced thermoplast, self-extinguishing
	Actuator	Stainless steel

- Note:**
1. Although the switch box is protected from dust or water penetration, do not use the D4DH in places where metal dust, water, or chemical may be sprayed onto the head, otherwise Switch damage or malfunctioning may occur.
 2. The above mechanical or electrical life is ensured at an ambient temperature of 5°C to 35°C and an ambient humidity of 40% to 70%.
 3. Be sure that the applied positive opening force and stroke are in conformity with the specified ranges.

Nomenclature

■ D4DH-□□BC

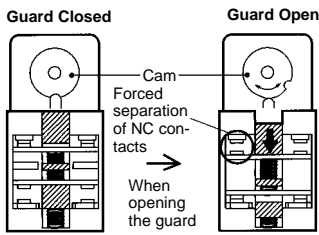

When the guard is opened, the cam that is directly coupled to the shaft rotates to press the Switch in the direction shown by the arrow. This action separates the contacts to stop the machine.

Built-in Switch
The built-in switch has a positive opening mechanism that forcibly separates the NC contact. Models with a 1NC contact and 1NO contact or 2NC contacts are available.

Cover
The cover, with a hinge on its lower part, can be opened by removing the screw of the cover, which ensures ease of maintenance and wiring.

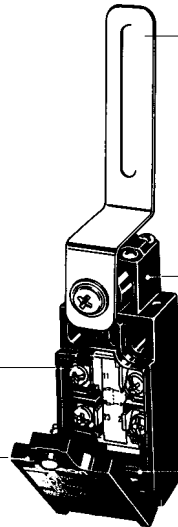

Arm Lever
The arm lever is mounted upwards in the center position before shipping. To change the position, loosen the arm lever mounting screw, dismount the arm lever, and mount the arm lever in the left or right position. The joint between the shaft and arm lever is formed with form-lock construction which remains secure even when the screw becomes loose. Arm lever and shaft are made of stainless steel.

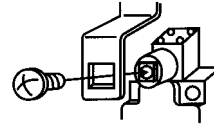

Head
The head can be mounted in four directions.

Conduit
A wide variety of conduits is available.

Size	1-conduit	2-conduit
Pg13.5	Yes	Yes
G1/2	Yes	Yes
1/2-14NPT	Yes	---

* The housing and head of the D4DH are made of resin. Use D4BS Miniature Electromagnetic Lock Safety Door Limit Switches for applications requiring safety door switches of tough, high-sealing, or oil-resistant construction.

Operation

■ Contact Form

Model	Contact	Contact form	Diagram	Remarks
D4DH-□5□□	1NC/1NO			<p>Only NC contact 11-12 has a positive opening mechanism. (→)</p> <p>The minimum positive opening travel is 45°. They can be used as opposing poles.</p>
D4DH-□A□□	2NC			<p>NC contacts 11-12 and 21-22 have a positive opening mechanism. (→)</p> <p>The minimum positive opening travel is 45°. They can be used as opposing poles.</p>

Note: Terminals are numbered according to EN50013. Contact forms are according to EN60947-5-1.

■ Positive Opening Mechanism

1NC/1NO Contact (Slow-action)

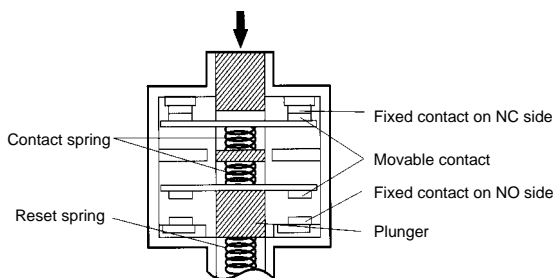

All models have slow-action contacts with approved positive opening mechanisms on the NC contacts, thus forcibly separating the NC contacts even if they weld. (Meets the requirements of EN60947-5-1.)

2NC Contact (Slow-action)

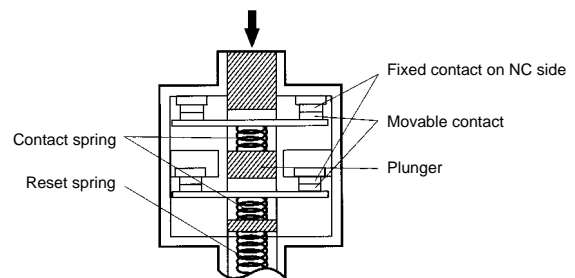

All models have slow-action contacts with approved positive opening mechanisms on the NC contacts, thus forcibly separating the NC contacts even if they weld. (Meets the requirements of EN60947-5-1.)

Dimensions

- Note:** 1. All units are in millimeters unless otherwise indicated.
 2. Each dimension has a tolerance of ± 0.4 mm unless otherwise specified.

Shaft Type with 1 Conduit

- D4DH-1□AS
- D4DH-2□AS
- D4DH-3□AS

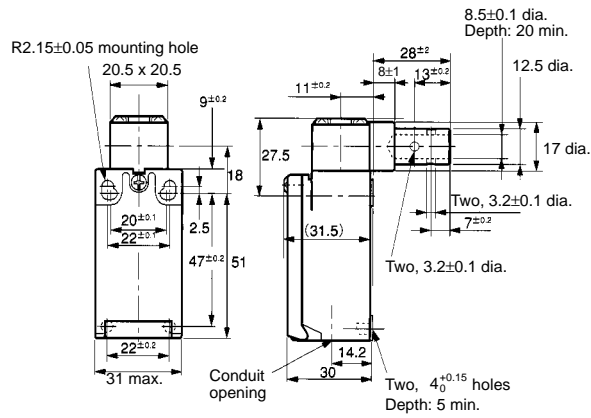

Shaft Type with 2 Conduits

- D4DH-5□AS
- D4DH-6□AS

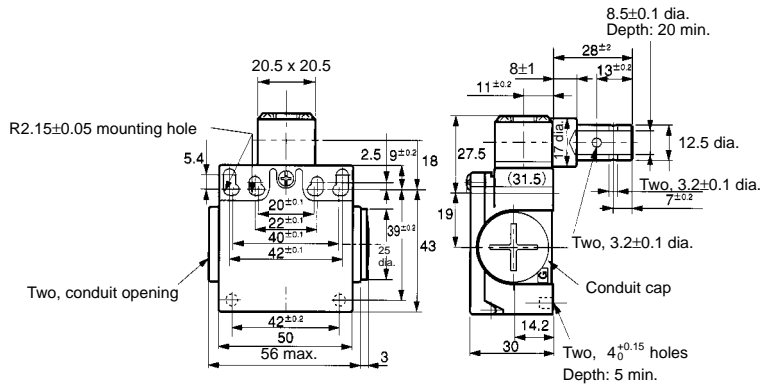
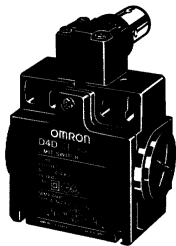

Arm Lever Type with 1 Conduit

- D4DH-1□BC
- D4DH-2□BC
- D4DH-3□BC

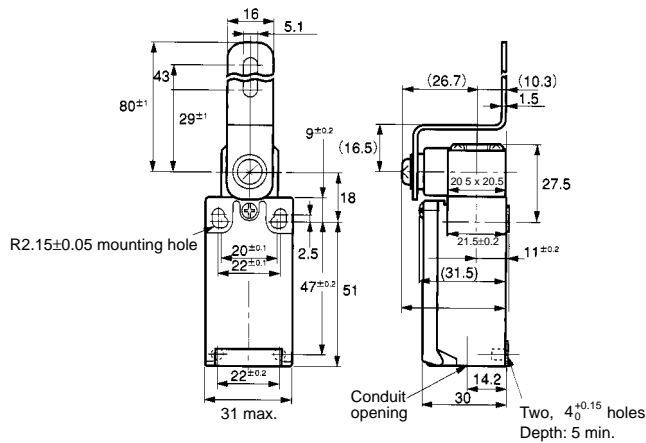
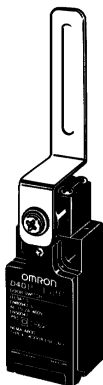

Arm Lever Type with 2 Conduits

D4DH-5□BC
D4DH-6□BC

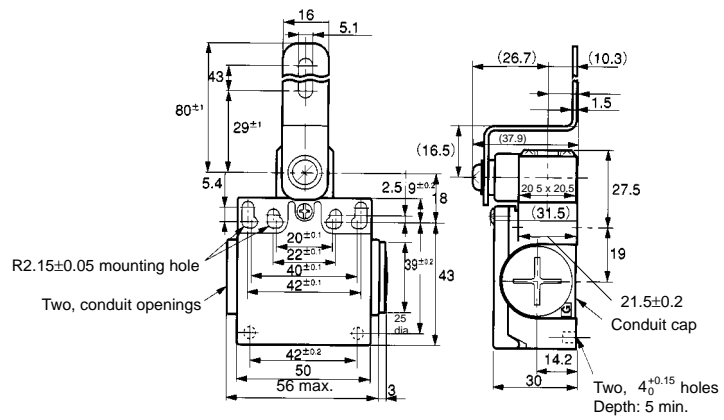
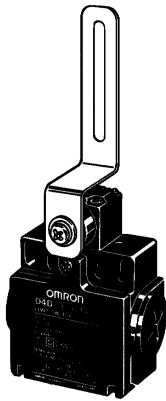

Operating force	0.15 N • m max.
Pre-travel angle 1 (NC)	(7°)
Pre-travel angle 2 (NO) (see note 2)	(19°)
Positive opening travel (min.)	45° min.
Positive opening force (min.)	1 N • m min.

Note: Applicable to models with 1NC and 1NO contacts.

Application Examples

■ Application Examples of Arm Lever Use

Note: Be sure to evaluate the Switch under actual working conditions after installation.

Shaft Actuator

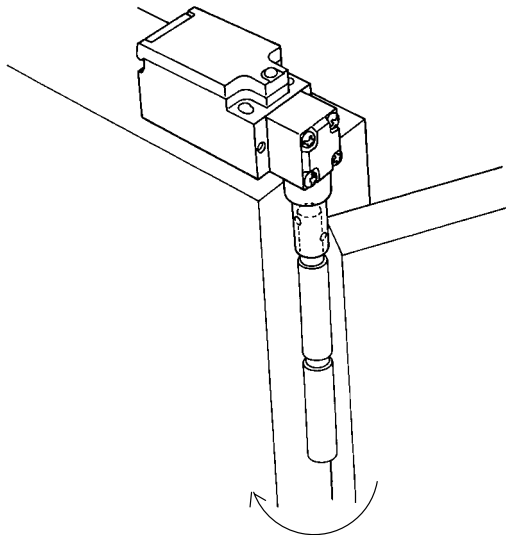

Arm Lever Actuator

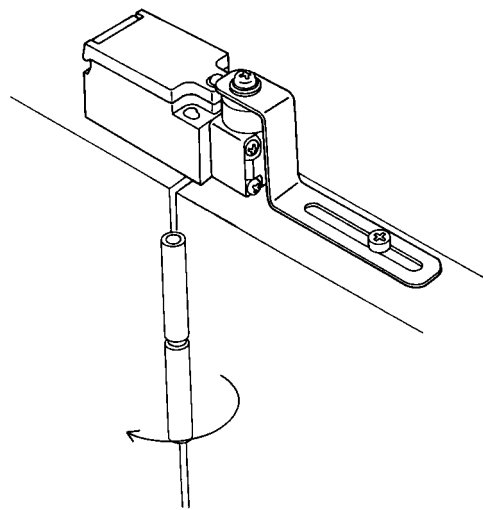

When Installing at the Center

The arm lever is set for center installation at the time of shipment.

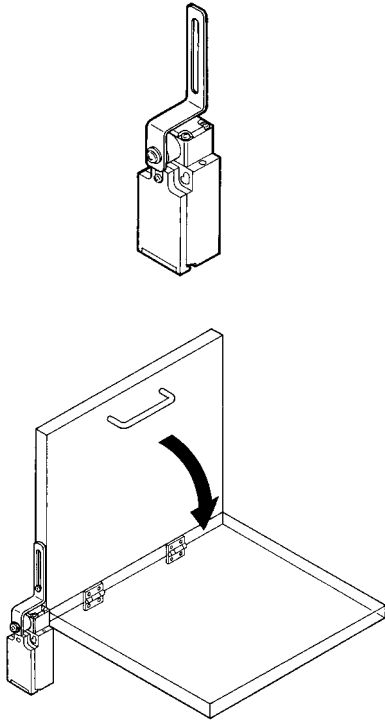

Note: Install the arm lever so that it will not rotate more than 90°. Otherwise, the lever will hit the switch body.

When Installing to the Left

When Installing to the Left

Remove the screw and arm lever, position the arm lever to the left, and then secure it with the screw.

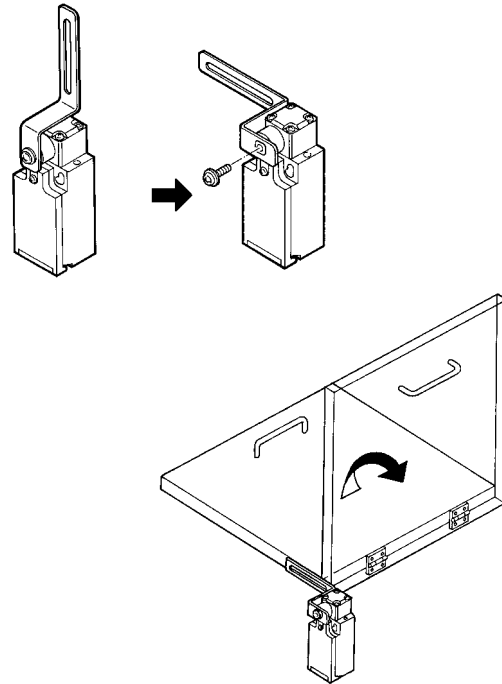

Note: Install the arm lever so that it will not rotate more than 180°. Otherwise, the lever will hit the switch body.

When Installing to the Right

Remove the screw and arm lever, position the arm lever to the right, and then secure it with the screw.

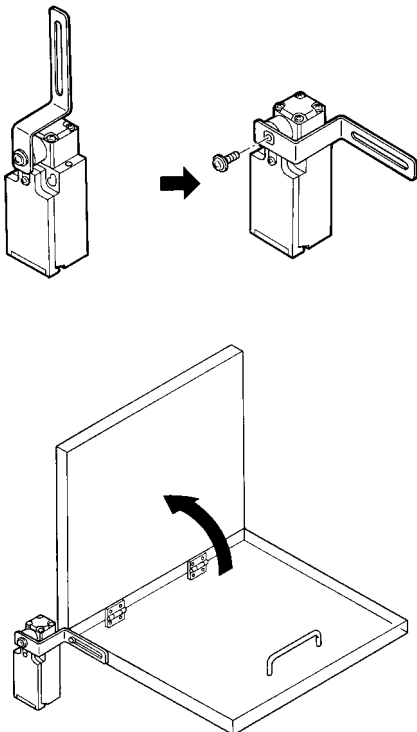

Note: Install the arm lever so that it will not rotate more than 180°. Otherwise, the lever will hit the switch body.

Precautions



CAUTION

Do not use metal connectors or conduits with this Switch. Rigid connectors and conduits may damage the Switch. The broken conduit hole may cause electrical shock hazard.

NOTICE

If the D4DH is applied to an emergency stop circuit or safety circuit for prevention of injury, use the NC contact, which incorporates a force-separation mechanism, and make sure that the D4DH operates in positive mode. Furthermore, secure the D4DH with screws or equivalent parts that are tightened in a single direction so that the D4DH or operation key cannot be easily removed or provide a protection cover to the D4DH and post a warning label near the D4DH.

Protect the D4DH with an appropriate cover and post a warning sign near the D4DH for safety reasons so that the D4DH will not be removed carelessly.

To protect the D4DH from damage due to short-circuits, connect the D4DH in series to a fuse that has a breaking current 1.5 to 2 times the rated current of the D4DH. If the D4DH is used under EN-approved rating conditions, use a 10-A fuse, type gI or gG conforming to IEC 269.

Do not touch the live switch terminal. Electric shock hazard may be caused.

Do not use the D4DH in locations subject to corrosive or flammable gases.

Make sure that the load current does not exceed the rated current and that the load terminals are wired correctly.

Pay utmost attention to correctly wire each terminal.

Be sure to evaluate the Switch under actual working conditions after installation.

Do not use the Switch as a stopper.

Do not drop or disassemble the D4DH.

Life Expectancy

The life of the D4DH will vary with the switching conditions. Before applying the D4DH, test the D4DH under actual operating conditions and be sure to use the D4DH in actual operation within switching times that will not lower the performance of the D4DH.

Operating Environment

The D4DH is for indoor use only. Do not use the D4DH outdoors. Otherwise, the D4DH may malfunction. Be sure that no metal dust, oil, or chemical will be sprayed onto the D4DH, otherwise the D4DH may malfunction.

Do not use the D4DH in the following locations:

Locations with severe changes in temperature

Locations with excessive humidity that may cause condensation

Locations with excessive vibration

Locations where metal dust, oil, or chemical may be sprayed onto the D4DH

Mounting Screw Tightening Torque

Be sure to tighten each screw of the D4DH properly, otherwise the D4DH may malfunction.

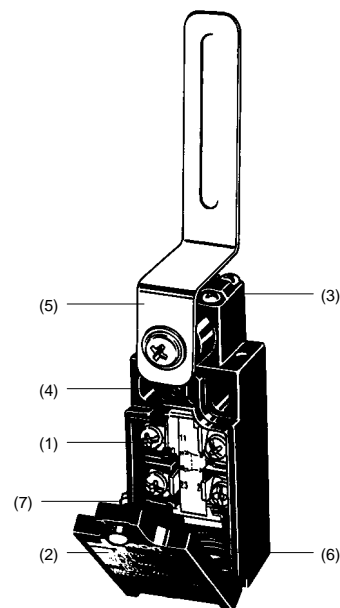

No.	Type	Torque
(1)	Terminal screw (M3.5)	0.59 to 0.78 N • m
(2)	Cover mounting screw	0.78 to 0.88 N • m
(3)	Head mounting screw	0.78 to 0.88 N • m
(4)	Body mounting screw (M4) (See note 1)	0.49 to 0.69 N • m
(5)	Arm lever mounting screw (M5 x 0.8)	1.57 to 1.77 N • m
(6)	Connector at conduit opening	1.77 to 2.16 N • m
		1.37 to 1.77 N • m (see note 2)
(7)	Cap screw (see note 3)	1.27 to 1.67 N • m

- Note:**
1. Tighten each screw together with a washer to the specified torque.
 2. This torque range applies to $1/2$ -14NPT connectors.
 3. For 2-conduit models only.

Mounting

Be sure the that D4DH operates properly after mounting and adjusting the D4DH.

Use two M4 screws (one-way screws, etc.) and washers to mount the D4DH securely. The D4DH can be mounted more securely with two protruding portions inserted into the lower part of the D4DH as shown below. Each protruding portion is $4 \begin{smallmatrix} -0.05 \\ -0.15 \end{smallmatrix}$ mm in diameter with a maximum height of 4.8 mm.

Mounting Holes

- Standard Model

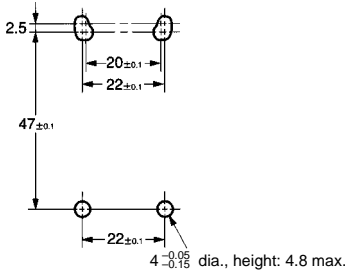

- 2-conduit Model

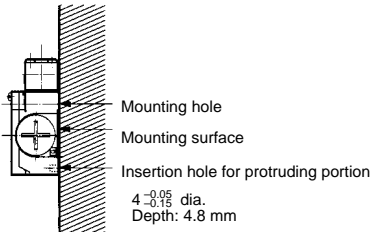
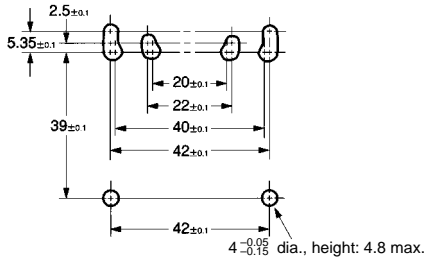

Mount the shaft or arm lever with a one-way screw, or an equivalent securely so that the shaft or arm lever cannot be easily dismounted. Although the shaft withstands a force exceeding 500 N, do not impose a force of 50 N or more on the shaft.

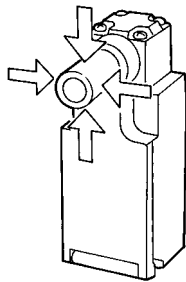

Be sure that the arm lever moves smoothly when the door opens or closes.

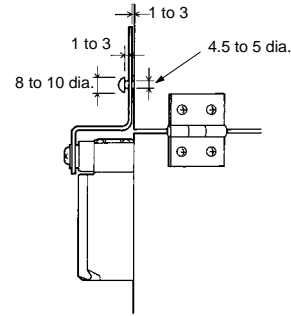

Arm Lever Mounting Position

The arm lever is mounted upwards in the center position before shipping. To change the position, loosen the arm lever mounting screw, dismount the arm lever, and mount the arm lever in the left or right position.

Head Direction

By removing the four screws of the head, the mounting direction of the head can be changed. The head can be mounted in four directions. Be sure that no foreign material will enter during a change in direction.

Wiring

Do not connect lead wires directly to the terminals. Be sure to connect the lead wires through insulation tubes and crimp terminals. The tightening torque applied to each crimp terminal is 0.59 to 0.78 N • m. The lead wires must be an AWG20 to AWG14 type (i.e., 0.5 to 2.5 mm² thick).

dz dia.:	3.7
D dia.:	4.5
B:	7.0
L:	20.2
F:	7.7
l:	9.0 (mm)

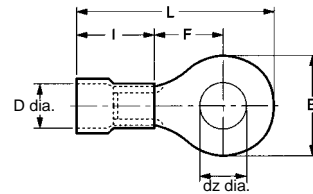

Wire the crimp terminal as shown in the following diagram so that it will not come in contact with the case or cover.

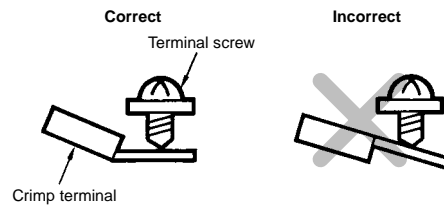

Conduit Opening

The torque required to tighten a connector other than a 1/2-14NPT connector is 1.77 to 2.16 N • m. The torque required to tighten a 1/2-14NPT connector is 1.37 to 1.77 N • m.

The casing may be damaged if an excessive tightening torque is applied. For the casing to maintain IP65, apply sealing tape between the connector and conduit opening. Be sure that the diameter of the cable connected to the connector is correct.

When wiring a 2-conduit model, attach and tighten a conduit cap to the unused conduit opening. The torque to be applied to the conduit cap is 1.27 to 1.67 N • m. The conduit cap is provided with the D4DH.

Recommended Connectors

Size	Manufacturer	Model	Cable diameter
G ¹ / ₂	OMRON	SC-6	7.5 to 9.0 mm
	LAPP	ST-PF1/2 5380-1022	6.0 to 12.0 mm
	Ohm Denki	OA-W1609	7.0 to 9.0 mm
Pg13.5	LAPP	ST13.5 5301-5030	5.0 to 12.0 mm
	HEYCO	3216	4.3 to 11.9 mm
1/2-14NPT	LAPP	ST-NPT1/2 5301-6030	6.0 to 12.0 mm
	HEYCO	3231	4.3 to 11.9 mm

Note: LAPP is a German manufacturer.
Ohm Denki is a Japanese manufacturer.
HEYCO is an American manufacturer.

Maintenance and Repairs

Please note in the machine manufacturer's instruction manual that the user must not repair or maintain the Switch and must contact the machine manufacturer for any repairs or maintenance.

Others

Use the D4BS under conditions requiring greater rigidity, sealing performance, and oil resistance.

ALL DIMENSIONS SHOWN ARE IN MILLIMETERS.

To convert millimeters into inches, multiply by 0.03937. To convert grams into ounces, multiply by 0.03527.