







**ART. 301** Raccordo diritto maschio conico  
Taper straight male adaptor

CODICE	ØD	F	I	H			
3010418	4/2,7	G <sub>1/8</sub>	8,0	25,5	9,0	12,0	100
3010518	5/3	G <sub>1/8</sub>	8,0	25,0	8,0	12,0	100
3010618	6/4	G <sub>1/8</sub>	8,0	26,5	12,0	12,0	100
3010614	6/4	G <sub>1/4</sub>	11,0	30,0	12,0	14,0	100
3010638	6/4	G <sub>3/8</sub>	11,5	30,5	12,0	17,0	100
3010818	8/6	G <sub>1/8</sub>	8,0	26,5	14,0	12,0	100
3010814	8/6	G <sub>1/4</sub>	11,0	30,0	14,0	14,0	100
3010838	8/6	G <sub>3/8</sub>	11,5	30,5	14,0	17,0	100
3010812	8/6	G <sub>1/2</sub>	14,0	33,5	14,0	22,0	50
3011018	10/8	G <sub>1/8</sub>	8,0	29,0	16,0	14,0	50
3011014	10/8	G <sub>1/4</sub>	11,0	32,0	16,0	14,0	50
3011038	10/8	G <sub>3/8</sub>	11,5	32,5	16,0	17,0	50
3011012	10/8	G <sub>1/2</sub>	14,0	35,5	16,0	22,0	50
3011238	12/10	G <sub>3/8</sub>	11,5	35,5	18,0	17,0	50
3011212	12/10	G <sub>1/2</sub>	14,0	38,5	18,0	22,0	50
3011512	15/12	G <sub>1/2</sub>	14,0	40,0	22,0	22,0	25

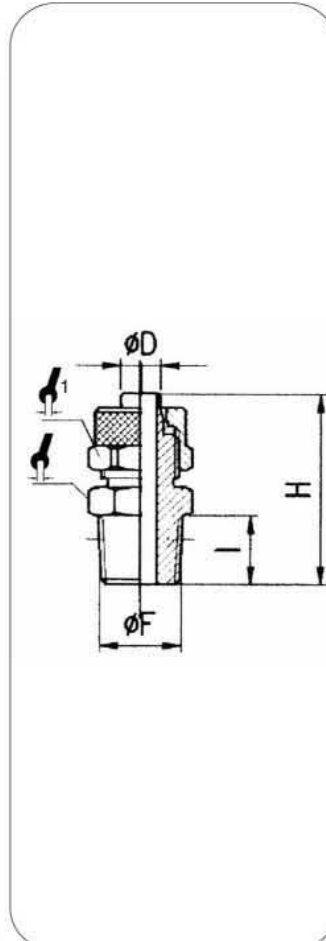

**ART. 301z** Raccordo diritto maschio cilindrico  
Parallel straight male adaptor

CODICE	ØD	F	I	H			
301Z04M5	4/2,7	M5	4,0	20,0	8,0	9,0	100
301Z0418	4/2,7	G <sub>1/8</sub>	6,0	21,5	8,0	13,0	100
301Z05M5	5/3	M5	4,0	20,0	8,0	8,0	100
301Z05M6	5/3	M6	4,0	22,1	8,0	8,0	100
301Z0518	5/3	G <sub>1/8</sub>	6,0	24,1	8,0	13,0	100
301Z06M5	6/4	M5	3,8	21,8	8,0	8,0	100
301Z0618	6/4	G <sub>1/8</sub>	6,0	24,5	12,0	13,0	100
301Z0614	6/4	G <sub>1/4</sub>	8,0	27,0	12,0	17,0	100
301Z0638	6/4	G <sub>3/8</sub>	9,0	28,0	12,0	19,0	100
301Z0818	8/6	G <sub>1/8</sub>	6,0	24,5	14,0	14,0	100
301Z0814	8/6	G <sub>1/4</sub>	8,0	27,0	14,0	17,0	50
301Z0838	8/6	G <sub>3/8</sub>	9,0	28,0	14,0	19,0	50
301Z1014	10/8	G <sub>1/4</sub>	8,0	29,0	16,0	17,0	50
301Z1038	10/8	G <sub>3/8</sub>	9,0	30,0	16,0	19,0	50
301Z1238	12/10	G <sub>3/8</sub>	9,0	33,0	18,0	19,0	50
301Z1212	12/10	G <sub>1/2</sub>	10,0	35,0	18,0	24,0	25
301Z1512	15/12	G <sub>1/2</sub>	10,0	35,0	22,0	24,0	25

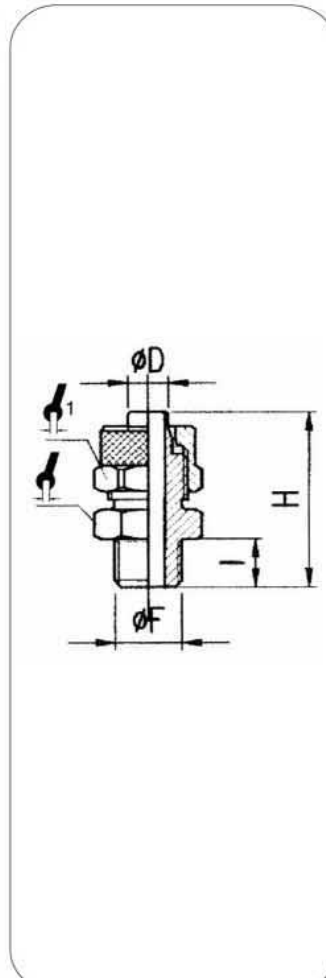

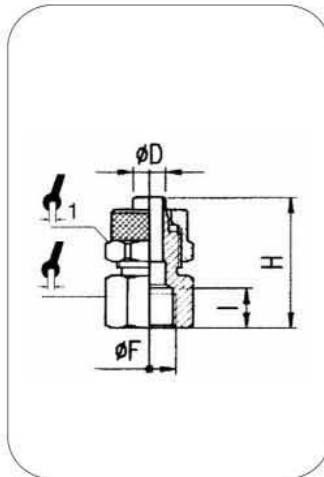

**ART. 302** Raccordo diritto femmina  
Straight female adaptor

CODICE	ØD	F	I	H			
3020618	6/4	G <sub>1/8</sub>	6,5	25,5		12,0	14,0
3020614	6/4	G <sub>1/4</sub>	8,0	27,5		12,0	17,0
3020638	6/4	G <sub>3/8</sub>	10,0	31,0		12,0	22,0
3020818	8/6	G <sub>1/8</sub>	6,5	25,5		14,0	14,0
3020814	8/6	G <sub>1/4</sub>	8,0	27,5		14,0	17,0
3020838	8/6	G <sub>3/8</sub>	10,0	31,0		14,0	22,0
3021014	10/8	G <sub>1/4</sub>	8,0	29,5		16,0	17,0
3021038	10/8	G <sub>3/8</sub>	10,0	33,0		16,0	22,0
3021238	12/10	G <sub>3/8</sub>	10,0	36,0		18,0	22,0

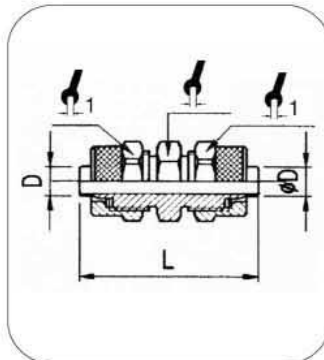

**ART. 303** Raccordo diritto intermedio  
Straight connector

CODICE	ØD	L					
3030500	5/3	28,5				8,0	8,0
3030600	6/4	32,0				12,0	12,0
3030800	8/6	32,0				14,0	12,0
3031000	10/8	37,0				16,0	14,0
3031200	12/10	43,0				18,0	17,0
3031500	15/12	46,5				22,0	22,0

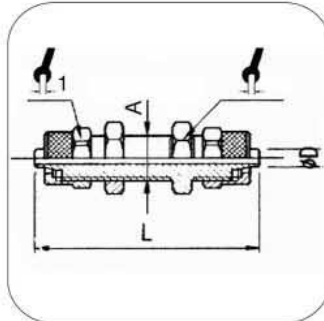

**ART. 304** Raccordo intermedio passaparete  
Bulkhead connector

CODICE	ØD	A	L				
3040600	6/4	M10X1	45,0			12,0	14,0
3040800	8/6	M12X1	48,0			14,0	17,0
3041000	10/8	M14X1	54,0			16,0	17,0
3041200	12/10	M16x1	57,0			18,0	19,0
3041500	15/12	M20x1	59,0			22,0	24,0

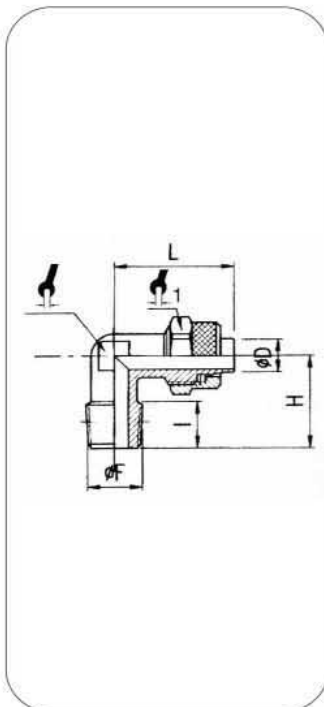



**ART. 305** Raccordo ad L maschio conico  
Elbow taper male adaptor

CODICE	ØD	F	I	H	L			
3050518	5/3	G <sub>1/8</sub>	8,0	17,0	21,5		8,0	8,0
3050618	6/4	G <sub>1/8</sub>	8,5	17,0	20,5		12,0	8,0
3050614	6/4	G <sub>1/4</sub>	12,5	21,0	20,5		12,0	8,0
3050638	6/4	G <sub>3/8</sub>	15,5	23,0	20,5		12,0	8,0
3050818	8/6	G <sub>1/8</sub>	8,0	17,0	20,5		14,0	10,0
3050814	8/6	G <sub>1/4</sub>	12,5	21,5	20,5		14,0	10,0
3050838	8/6	G <sub>3/8</sub>	15,3	23,8	20,5		14,0	10,0
3050812	8/6	G <sub>1/2</sub>	16,5	25,0	20,5		14,0	10,0
3051018	10/8	G <sub>1/8</sub>	8,0	17,0	24,5		16,0	12,0
3051014	10/8	G <sub>1/4</sub>	12,5	22,0	24,5		16,0	12,0
3051038	10/8	G <sub>3/8</sub>	14,8	24,3	24,5		16,0	12,0
3051012	10/8	G <sub>1/2</sub>	14,0	28,0	28,0		16,0	17,0
3051238	12/10	G <sub>3/8</sub>	14,0	26,0	29,0		18,0	14,0
3051212	12/10	G <sub>1/2</sub>	16,0	28,0	29,0		18,0	14,0
3051512	15/12	G <sub>1/2</sub>	15,0	28,0	24,0		22,0	16,0



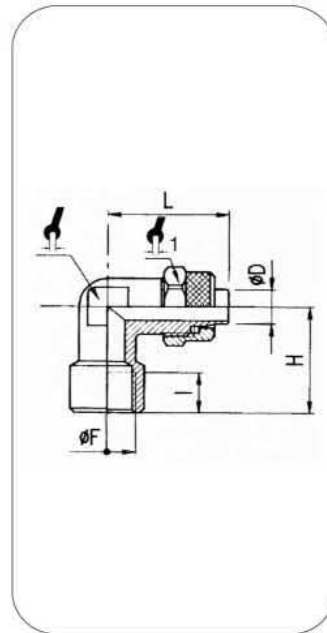

**ART. 305F** Raccordo ad L femmina  
Female elbow adaptor

CODICE	ØD	F	I	H	L			
305F0618	6/4	G <sub>1/8</sub>	7,0	20,5	20,5	12,0	8,0	100
305F0614	6/4	G <sub>1/4</sub>	8,0	22,5	20,5	12,0	8,0	50
305F0818	8/6	G <sub>1/8</sub>	7,0	20,5	20,5	14,0	10,0	100
305F0814	8/6	G <sub>1/4</sub>	8,0	23,5	20,5	14,0	10,0	50
305F1014	10/8	G <sub>1/4</sub>	8,0	24,0	24,5	16,0	12,0	50
305F1038	10/8	G <sub>3/8</sub>	10,0	27,0	24,5	16,0	12,0	25
305F1238	12/10	G <sub>3/8</sub>	10,0	29,0	29,0	18,0	14,0	25



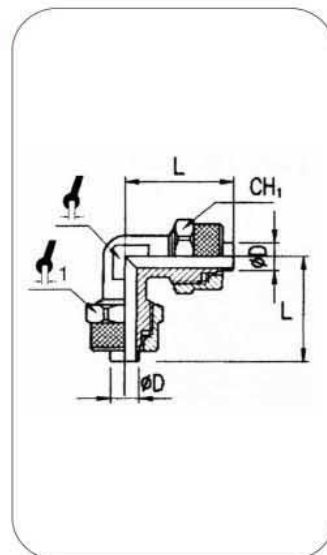

**ART. 306** Raccordo ad L intermedio  
Elbow connector

CODICE	ØD	L			
3060600	6/4	20,5	12,0	8,0	100
3060800	8/6	20,5	14,0	10,0	100
3061000	10/8	24,5	16,0	12,0	50
3061200	12/10	29,0	18,0	14,0	25
3061500	15/12	34,0	22,0	16,0	25



**ART. 307** Raccordo T centrale  
Central Tee adaptor

CODICE	ØD	F	I	H	L			
3070618	6/4	G <sub>1/8</sub>	8,5	17,0	41,0	12,0	8,0	100
3070614	6/4	G <sub>1/4</sub>	13,0	21,5	41,0	12,0	8,0	50
3070818	8/6	G <sub>1/8</sub>	8,0	16,5	41,0	14,0	10,0	50
3070814	8/6	G <sub>1/4</sub>	12,5	21,0	41,0	14,0	10,0	50
3070838	8/6	G <sub>3/8</sub>	15,3	23,8	41,0	14,0	10,0	50
3071018	10/8	G <sub>1/8</sub>	8,0	18,5	49,0	16,0	12,0	50
3071014	10/8	G <sub>1/4</sub>	11,8	22,3	49,0	16,0	12,0	50
3071038	10/8	G <sub>3/8</sub>	14,7	25,2	49,0	16,0	12,0	25
3071238	12/10	G <sub>3/8</sub>	14,1	26,0	58,0	18,0	14,0	25
3071212	12/10	G <sub>1/2</sub>	15,0	27,0	58,0	18,0	14,0	25
3071512	15/12	G <sub>1/2</sub>	14,4	27,4	68,0	22,0	16,0	10

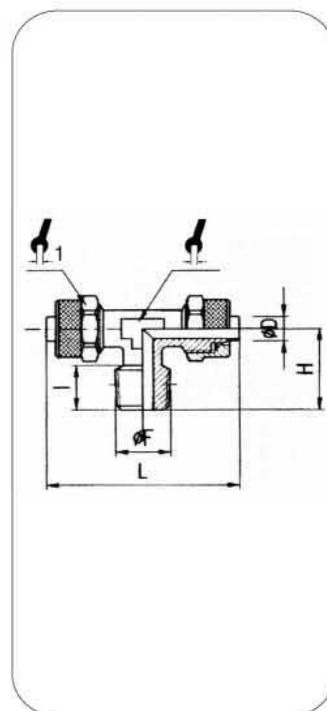

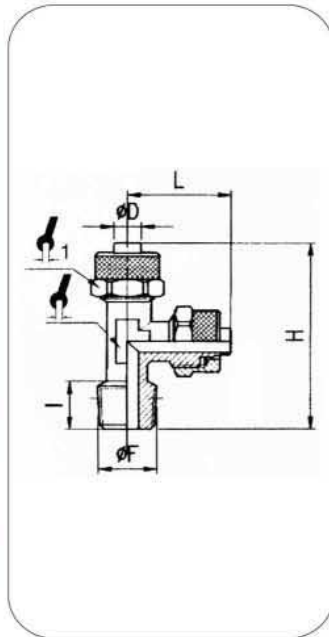

**ART. 308** Raccordo T laterale  
Off-set Tee adaptor

CODICE	ØD	F	I	L	H			
3080618	6/4	G <sub>1/8</sub>	8,5	20,5	37,5	12,0	8,0	100
3080614	6/4	G <sub>1/4</sub>	13,0	20,5	42,0	12,0	8,0	50
3080818	8/6	G <sub>1/8</sub>	8,0	20,5	37,0	14,0	10,0	50
3080814	8/6	G <sub>1/4</sub>	12,5	20,5	41,5	14,0	10,0	50
3080838	8/6	G <sub>3/8</sub>	15,3	20,5	44,3	14,0	10,0	50
3081018	10/8	G <sub>1/8</sub>	8,0	25,5	44,0	16,0	12,0	50
3081014	10/8	G <sub>1/4</sub>	11,8	24,5	46,8	16,0	12,0	50
3081038	10/8	G <sub>3/8</sub>	14,7	24,5	49,7	16,0	12,0	25
3081238	12/10	G <sub>3/8</sub>	14,1	29,0	55,1	18,0	14,0	25
3081212	12/10	G <sub>1/2</sub>	15,0	29,0	56,0	18,0	14,0	20
3081512	15/12	G <sub>1/2</sub>	14,4	34,0	61,4	22,0	16,0	10

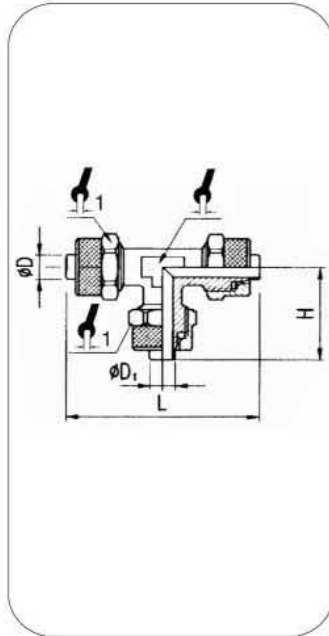

**ART. 309** Raccordo T intermedio  
Tee connector

CODICE	ØD	H	L			
3090600	6/4	20,5	41,0	12,0	8,0	50
3090800	8/6	20,5	41,0	14,0	10,0	50
3091000	10/8	24,5	49,0	16,0	12,0	25
3091200	12/10	29,0	58,0	18,0	14,0	25
3091500	15/12	34,0	68,0	22,0	16,0	10

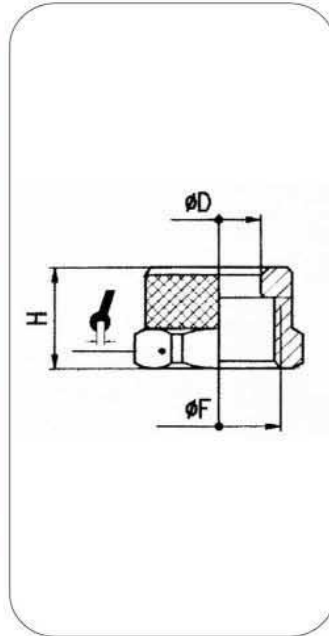

**ART. 310** Dado di serraggio  
Locking nut

CODICE	ØD	F	H		
3100400	4/2,7	M7x0,75	10,0	7,0	100
3100500	5/3	M7x0,75	10,0	8,0	100
3100608	6/4	M8x0,75	11,0	8,0	100
3100610	6/4	M10x1	11,0	12,0	100
3100800	8/6	M12x1	11,5	14,0	100
3101000	10/8	M14x1	13,5	16,0	100
3101200	12/10	M16x1	15,0	18,0	100
3101500	15/12	M20x1	14,5	22,0	50