

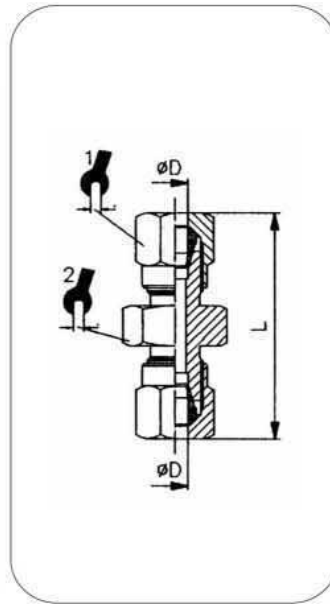

## ART. 203 Raccordo diritto intermedio Straight connector

CODICE	ØD	L			
2030400	4,0	35,0		10,0	50
2030600	6,0	36,5		12,0	50
2030800	8,0	38,5		14,0	50
2031000	10,0	47,5		19,0	25
2031200	12,0	50,5		22,0	25
2031400	14,0	55,5		27,0	25
2031500	15,0	55,5		27,0	25



## ART. 204 Raccordo passaparete Bulkhead adaptor

CODICE	ØD	L			
2040600	6,0	48,0		12,0	50
2040800	8,0	53,0		14,0	50
2041000	10,0	58,0		17,0	25
2041200	12,0	66,0		19,0	25
2041500	15,0	69,5		27,0	10

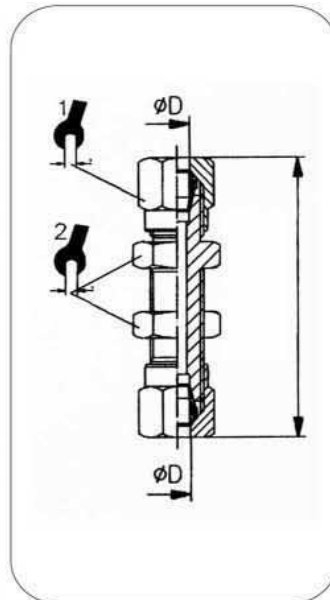

## ART. 205 Raccordo ad L Elbow male adaptor

CODICE	ØD	A	B	C	L			
2050418	4,0	G <sub>1/8</sub>	7,5	16,0	21,0		10,0	100
2050618	6,0	G <sub>1/8</sub>	7,5	16,0	23,0		12,0	100
2050614	6,0	G <sub>1/4</sub>	11,0	20,0	24,5		12,0	100
2050818	8,0	G <sub>1/8</sub>	7,5	17,0	24,0		14,0	100
2050814	8,0	G <sub>1/4</sub>	11,0	20,0	24,0		14,0	100
2050838	8,0	G <sub>3/8</sub>	11,0	26,5	32,5		14,0	50
2051014	10,0	G <sub>1/4</sub>	11,0	23,5	32,0		19,0	50
2051038	10,0	G <sub>3/8</sub>	11,5	24,0	32,0		19,0	50
2051012	10,0	G <sub>1/2</sub>	14,0	30,0	33,0		17,0	25
2051238	12,0	G <sub>3/8</sub>	11,0	26,5	33,0		19,0	25
2051212	12,0	G <sub>1/2</sub>	14,0	30,0	33,0		19,0	25
2051412	14,0	G <sub>1/2</sub>	14,0	30,0	39,0		22,0	25
2051512	15,0	G <sub>1/2</sub>	14,0	30,0	37,0		24,0	20
2051612	16,0	G <sub>1/2</sub>	14,0	31,5	39,5		30,0	10
2051812	18,0	G <sub>1/2</sub>	14,0	34,0	44,0		32,0	10

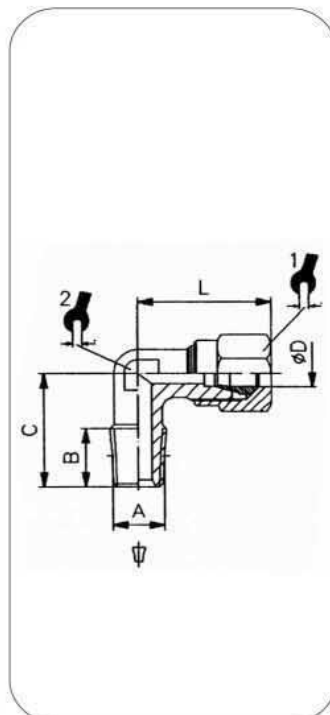

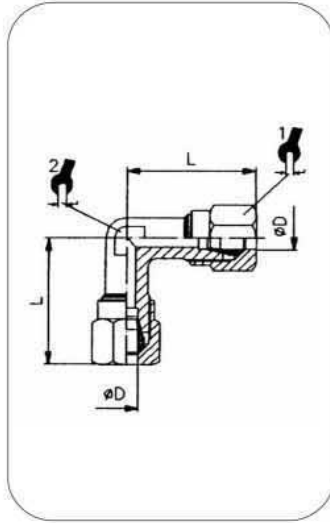

**ART. 206** Raccordo ad L intermedio  
Elbow connector

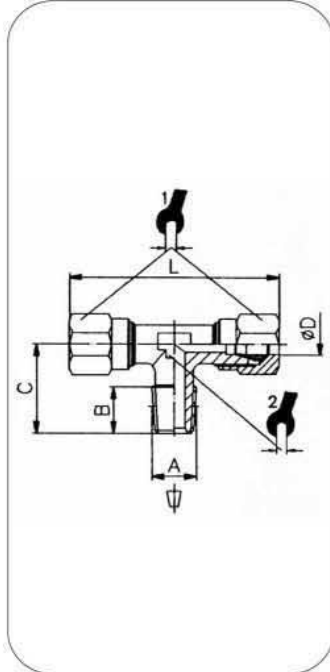
CODICE	$\varnothing D$	L						
2060400	4,0	27,0				10,0	11,0	100
2060600	6,0	28,0				12,0	11,0	50
2060800	8,0	28,5				14,0	11,0	50
2061000	10,0	32,0				17,0	14,0	25
2061200	12,0	35,0				19,0	13,0	25
2061400	14,0	39,0				22,0	17,0	25
2061500	15,0	40,0				24,0	17,0	20

**ART. 207** Raccordo a T centrale  
Centre male tee adaptor

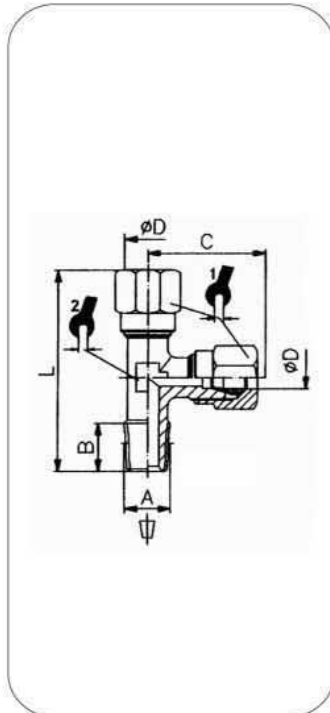
CODICE	$\varnothing D$	A	B	C	L			
2070418	4,0	G <sub>1/8</sub>	8,0	16,0	42,0	10,0	9,0	100
2070618	6,0	G <sub>1/8</sub>	8,0	16,0	46,0	12,0	9,0	50
2070614	6,0	G <sub>1/4</sub>	11,0	20,0	48,0	12,0	11,0	50
2070818	8,0	G <sub>1/8</sub>	8,0	17,0	48,0	14,0	11,0	50
2070814	8,0	G <sub>1/4</sub>	11,0	20,0	48,0	14,0	11,0	50
2070838	8,0	G <sub>3/8</sub>	11,5	24,0	54,0	14,0	13,0	25
2071014	10,0	G <sub>1/4</sub>	11,0	23,5	64,0	19,0	13,0	25
2071038	10,0	G <sub>3/8</sub>	11,5	24,0	64,0	19,0	13,0	25
2071238	12,0	G <sub>3/8</sub>	11,5	25,5	69,0	22,0	15,0	25
2071212	12,0	G <sub>1/2</sub>	14,0	28,5	69,0	22,0	15,0	20

**ART. 208** Raccordo a T laterale  
Off-set male tee adaptor

CODICE	$\varnothing D$	A	B	C	L			
2080418	4,0	G <sub>1/8</sub>	8,0	22,5	38,5	10,0	9,0	100
2080618	6,0	G <sub>1/8</sub>	8,0	23,5	39,5	12,0	9,0	100
2080614	6,0	G <sub>1/4</sub>	11,0	25,0	45,0	12,0	10,0	50
2080818	8,0	G <sub>1/8</sub>	8,0	26,5	46,5	14,0	12,0	50
2080814	8,0	G <sub>1/4</sub>	11,0	28,0	47,5	14,0	10,0	50
2080838	8,0	G <sub>3/8</sub>	11,0	34,5	58,5	14,0	13,0	25
2081014	10,0	G <sub>1/4</sub>	11,0	30,0	53,0	17,0	12,0	25
2081038	10,0	G <sub>3/8</sub>	11,0	34,0	60,0	17,0	13,0	25
2081238	12,0	G <sub>3/8</sub>	11,0	34,0	60,0	19,0	13,0	20
2081212	12,0	G <sub>1/2</sub>	14,0	36,0	64,0	19,0	17,0	20

**ART. 209** Raccordo a T intermedio  
Tee connector

CODICE	ØD	C	L			
2090400	4,0	21,0	42,0	10,0	9,0	50
2090600	6,0	23,0	46,0	12,0	9,0	50
2090800	8,0	24,0	48,0	14,0	11,0	25
2091000	10,0	30,0	60,0	17,0	12,0	25
2091200	12,0	34,0	68,0	19,0	13,0	20

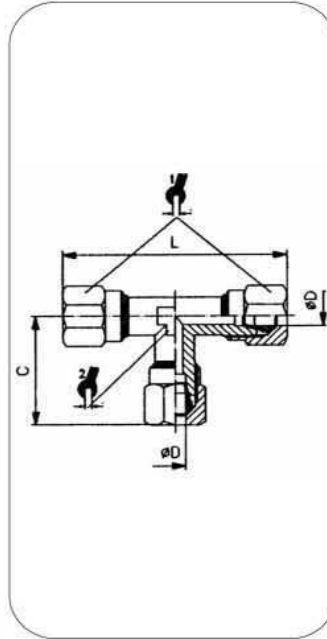

**ART. 210** Dado  
Nut

CODICE	ØD	A		
2100400	4,0	M8x1,0	10,0	100
2100600	6,0	M10x1,0	12,0	100
2100800	8,0	M12x1,0	14,0	100
2101000	10,0	M16x1,0	19,0	100
2101200	12,0	M18x1,0	22,0	100

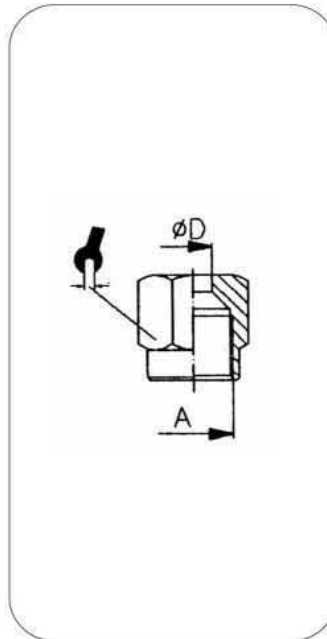

**ART. 211** Ogiva  
Ogive

CODICE	ØD			
2110400	4,0			100
2110600	6,0			100
2110800	8,0			100
2111000	10,0			100
2111200	12,0			100
2111500	15,0			100

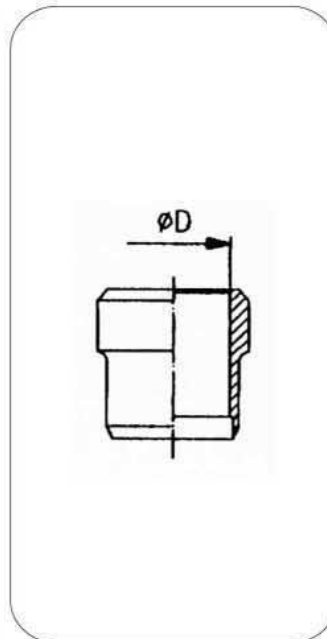

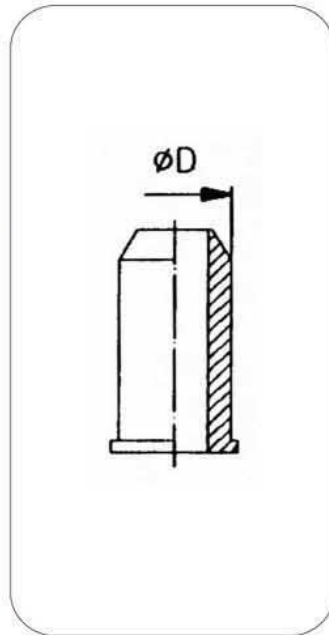

**ART. 212** Boccola di supporto  
Support bush

CODICE	ØD						
2120200	2,0						100
2120400	4,0						100
2120600	6,0						100
2120800	8,0						100
2121000	10,0						100
2121200	12,0						100

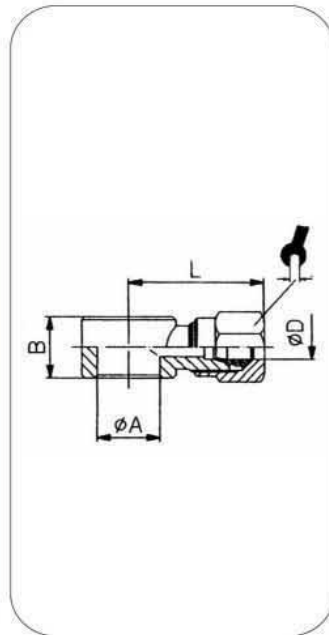

**ART. 216** Raccordo ad L orientabile  
Single banjo body

CODICE	ØD	G	ØA	B	L		
2160418	4,0	G <sub>1/8</sub>	9,8	14,5	24,5	10,0	100
2160618	6,0	G <sub>1/8</sub>	9,8	14,5	26,5	12,0	100
2160614	6,0	G <sub>1/4</sub>	13,2	14,5	28,5	12,0	100
2160818	8,0	G <sub>1/8</sub>	9,8	14,5	25,5	14,0	100
2160814	8,0	G <sub>1/4</sub>	13,2	14,5	28,0	14,0	100
2161014	10,0	G <sub>1/4</sub>	13,3	14,5	32,0	17,0	100