



Construction and working characteristics

- Filter - diaphragm pressure regulator with relieving.
- Balanced poppet.
- Double filtering action: by air centrifuging and by replaceable and reusable HDPE porous filter element.
- Zinc alloy body reinforced technopolymer body with threaded brass insert connections
- Wall mounting possibility with M4 screws protected by covers.
- Lockable handle by simply pressing it downwards in the desired position.
- Transparent technopolymer bowls screwed to the body.
- Shock resistant bowl technopolymer protections.
- Manual and semi-automatic water drain valve; in the semi-automatic version the drainage happens when there is no pressure or by pushing the valve up-wards.
- Possibility to see the water level on 360° also with bowl protection assembled.
- Two pressure gauge connections with plug complete of seal.
- Panel mounting bracket.
- Automatic water drainage bowl available on request.
- Fog type lubrication with variable section orifice according to the flow.
- Possibility to see the min. and max. oil level on 360° also with bowl protection assembled.
- Transparent technopolymer sight dome with adjusting handle.
- Oil filling plug.

Technical characteristics

Connections	G 1/8" - G 1/4"
Max. inlet pressure	13 bar - 1,3 MPa
Max. ambient temperature (at 10 bar)	50°C
Pressure gauge connections	G 1/8"
Weight with technopolymer body	gr. 295
Weight with zinc alloy body	gr. 560
Pressure range	0 - 2 bar 0 - 4 bar 0 - 8 bar 0 - 12 bar
Filter pore size	5µ 20µ 50µ
Bowl capacity	17 cm ³
Indicative oil drip rate	1 drop every 300/600 NI
Oil type	FD22 - HG32
Bowl capacity	32 cm ³
Assembly position	Vertical
Wall mounting screws	M4
Max. fitting torque on zinc alloy body	30 Nm
Max. fitting torque on technopolymer body	15 Nm
Min. operational flow at 6.3 bar	10 NI/min

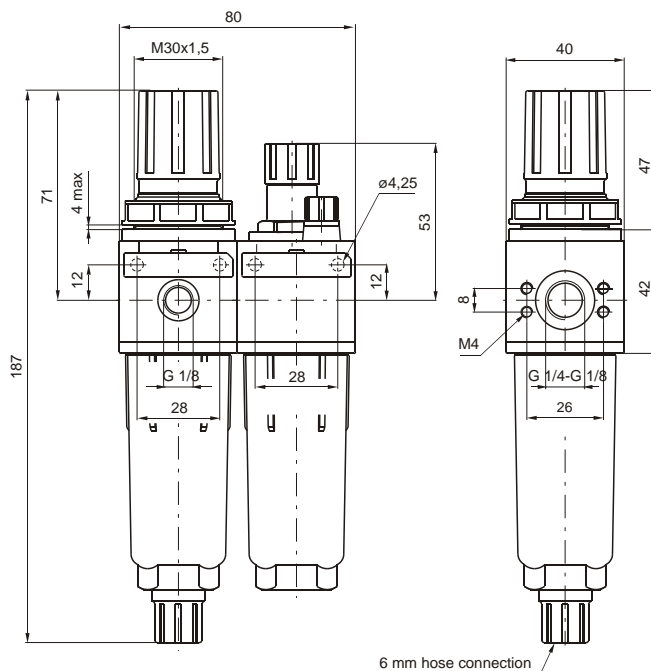

Flow rate curves
 Inlet pressure (7 bar)

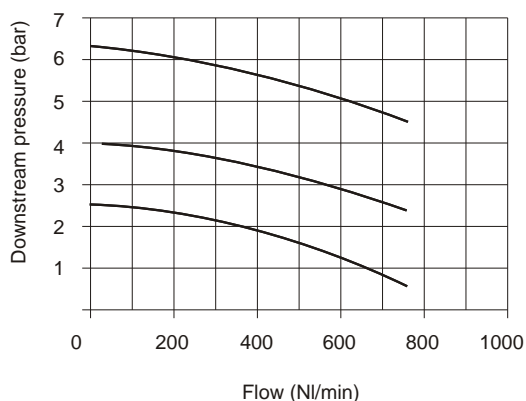

Adjustment characteristics

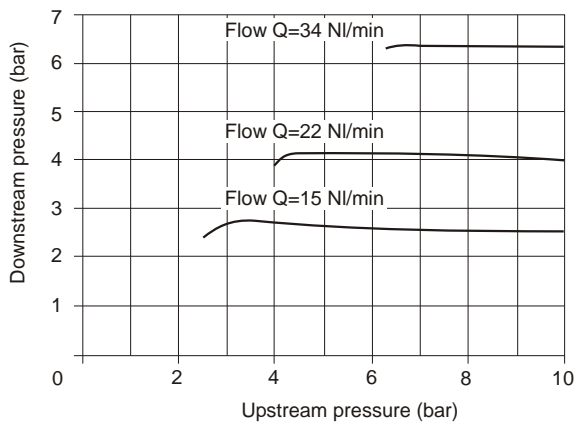

Ordering code

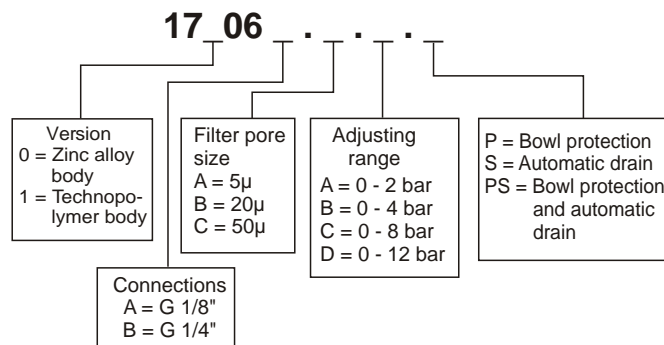

Example: **17106A.B.C.P**

Service unit combination complete with filter - pressure regulator and lubricator size 1 G 1/8" connections, filter pore size 20μ, adjusting range 0-8 bar and bowl protections with technopolymer body.