

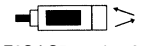

Sensing distance	Supply voltage	Output
 E3S-LS5: 4 to 6 cm E3S-LS10: 4 to 10 cm E3S-LS20: 4 to 20 cm	12 to 24 VDC	 100 mA

Distance-settable Photoelectric Sensor

E3S-LS5/LS10/LS20

Precise Sensing of Objects Independent of Color, Material and Background

- Adjustable sensing distance allows for sensing against any background.
- Operates independent of object's color, material and shape.
- Small differential travel makes possible the sensing of small deviations in object's position.
- Visible light spot allows for easy checking of sensing position. (E3S-LS5)



Ordering Information

Method of sensing	Settable distance	Operating mode	Output transistor	Model
Distance-settable diffuse reflective	4 to 6 cm	Light-ON/Dark-ON (switch selectable)	NPN	E3S-LS5C4S
	4 to 10 cm		PNP	E3S-LS5B4S1
	4 to 20 cm		NPN	E3S-LS10C4S
			NPN	E3S-LS20C4S
			PNP	E3S-LS20B4S1

Application Examples

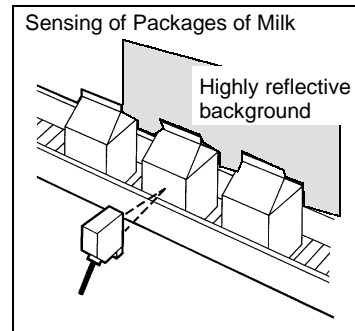
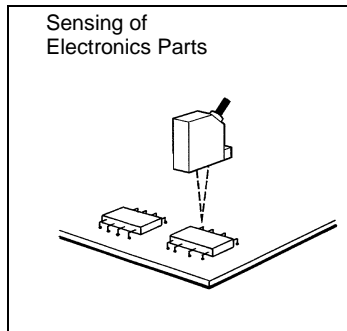
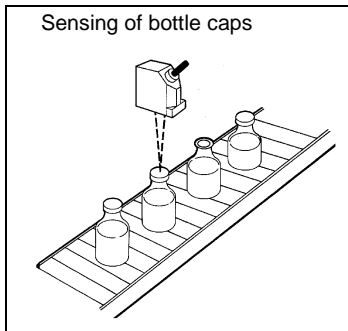

Specifications

Item	E3S-LS20j 4Sj	E3S-LS10C4S	E3S-LS5j 4Sj
LED for Emitter (wavelength)	Infrared LED (890 nm)	Red LED (700 nm)	
Operation indicator	Light indicator (red), stability indicator (green)		
Sensitivity adjustment	Two-turn adjustor with an indicator		
Connection method	Pre-wired		
Materials	Case: Heat-resistive ABS Lens cover: Polyallylate Mounting bracket: Stainless steel		

■ Ratings/Characteristics

Item	E3S-LS5j 4Sj	E3S-LS10C4S	E3S-LS20j 4Sj
Power supply voltage	12 to 24 VDC $\pm 10\%$, ripple (p-p): 10% max.		
Current consumption	35 mA max.		
Adjustable sensing distance	4 to 6 cm (white paper, 1 x 1 cm)	4 to 10 cm (white paper, 2.5 x 2.5 cm)	4 to 20 cm (white paper, 5 x 5 cm)
Sensing range (white paper, sensitivity set to max.) (see note 1)	0.5 to 6 cm	0.5 to 10 cm	0 to 20 cm
Minimum sensing object (steel, sensitivity set to max.)	0.2 mm dia. (sensing distance: 40 to 50 mm)		0.3 mm dia. (sensing distance: 40 mm)
Differential travel	2 mm	3 mm max.	15% max. of sensing distance
Reflection characteristics	$\pm 10\%$ max. (black paper, reflection rate: 5%)		
Gradient characteristics (white paper)	$\pm 10\%$ max. (at $\pm 45^\circ$)		
Light source spot size	3 mm dia. max.	7.5 mm dia. max.	20 mm dia. max.
Response time	1 ms max.	5 ms max.	2 ms max.
Output	Control output: 100 mA at 24 VDC (residual voltage: 1 V max.) Self-diagnostic output: 50 mA at 24 VDC (residual voltage: 1 V max.)		
Operating mode	Light-ON/Dark-ON (switch selectable)		
Connection method (see note 2)	4-conductive cable (2 m): V_{CC} : Brown (red) 0 V: Blue (black) Control output: Black (white) Self-diagnostic output: Orange (orange)		
Ambient illumination	Incandescent lamp: 3,000 lx max.		
Ambient temperature	Operating: -25°C to 55°C Storage: -40°C to 70°C		
Ambient humidity	Operating: 35% to 85% Storage: 35% to 95%		
Temperature characteristics	Change in sensing distance within $\pm 10\%$		
Vibration resistance	Destruction: 10 to 55 Hz, 1.5-mm double amplitude for 2 hrs each in X, Y, and Z directions		
Shock resistance	Destruction: 500 m/s ² (approx. 50G) for 3 times each in X, Y, and Z directions		
Enclosure rating	IEC IP67		
Insulation resistance	20 M Ω min. (at 500 VDC)		
Dielectric strength	1,000 VAC, 50/60 Hz for 1 min		

- Note:**
- Setting distance is not possible though sensing objects at this distance is possible.
 - The colors shown in brackets indicate old cable colors.

Engineering Data

Sensing Object Size vs. Sensing Distance (Typical)

E3S-LS5

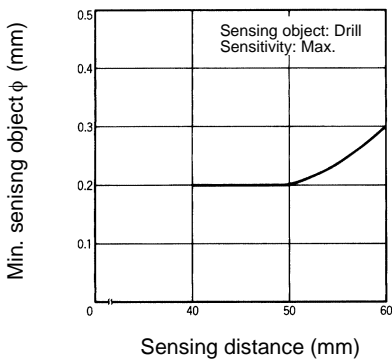

E3S-LS10

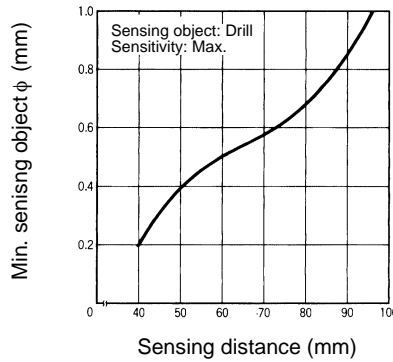

E3S-LS20

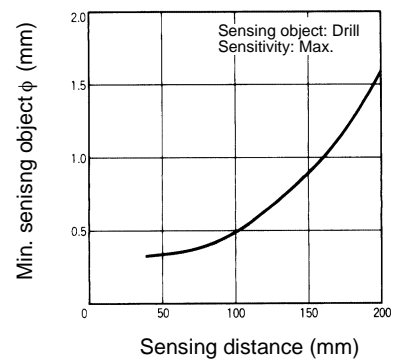

Spot Diameter vs. Sensing Distance (Typical)

E3S-LS5

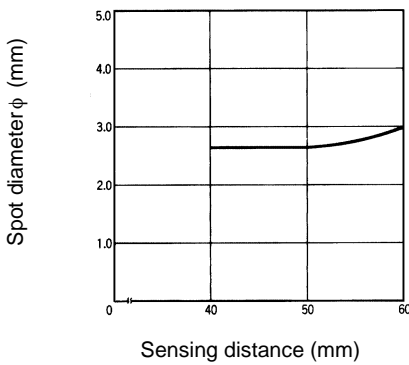

E3S-LS10

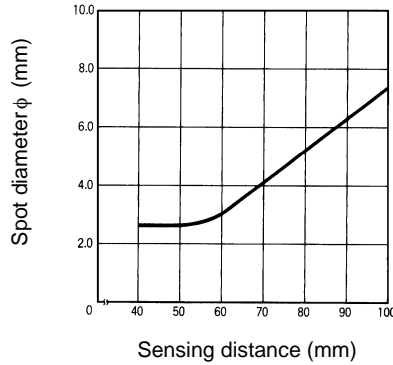

E3S-LS20

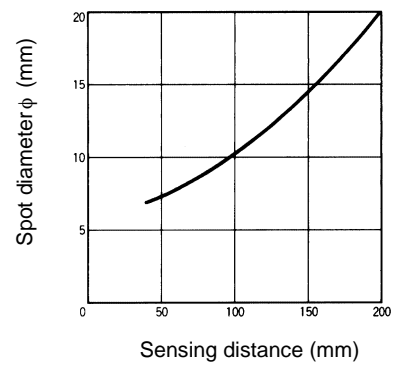

Operating Range (Typical)

E3S-LS5

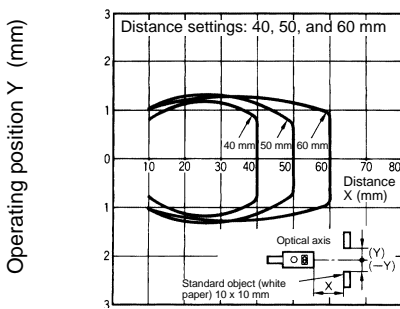

E3S-LS10

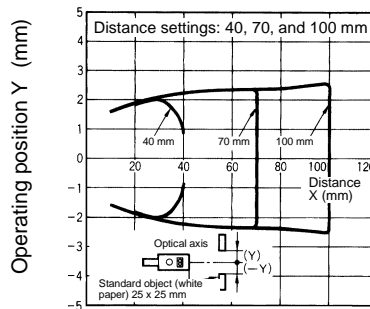

E3S-LS20

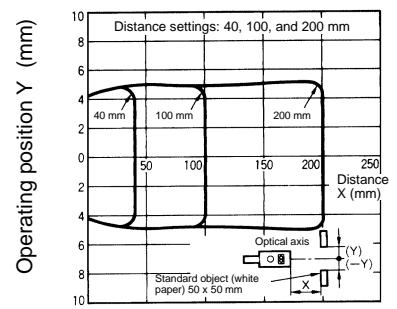

Gradient Characteristics (Typical)

E3S-LS5 (Vertical Direction)

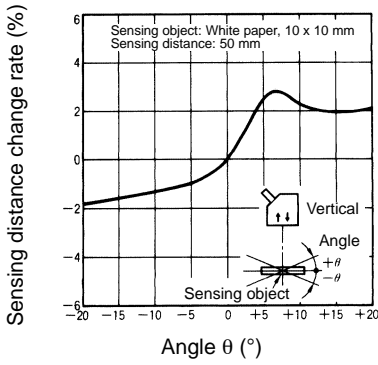

E3S-LS10 (Vertical Direction)

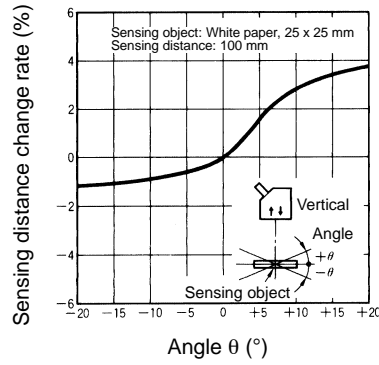

E3S-LS20 (Vertical Direction)

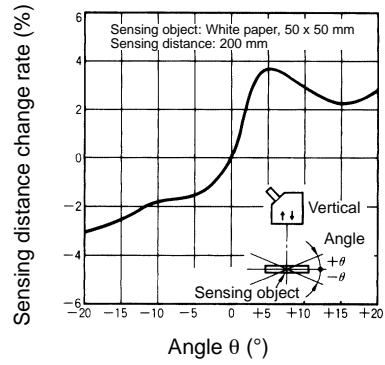

E3S-LS5 (Horizontal Direction)

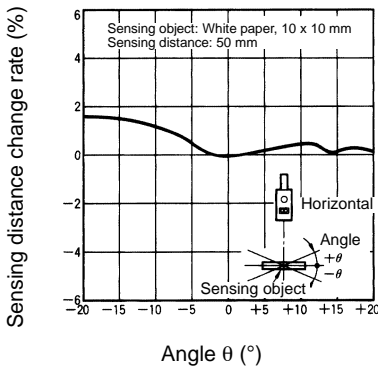

E3S-LS10 (Horizontal Direction)

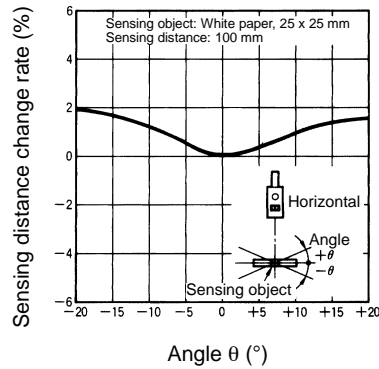

E3S-LS20 (Horizontal Direction)

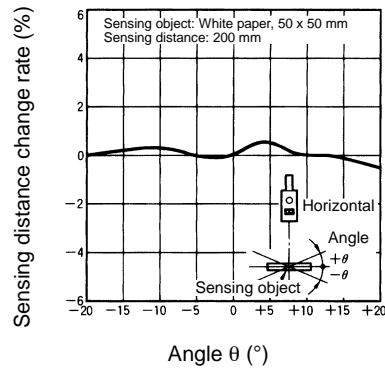

Sensing Distance vs. Materials (Typical)

E3S-LS5j

Sensing of White Paper at a Setting Distance of 60 mm

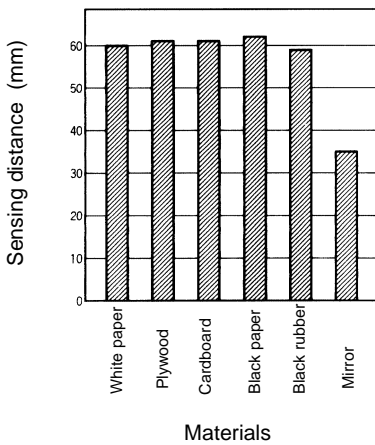

Sensing of White Paper at a Setting Distance of 50 mm

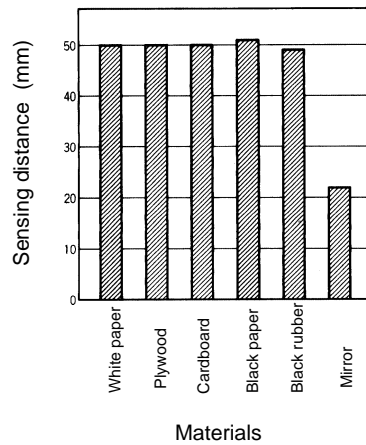

Sensing of White Paper at a Setting Distance of 40 mm

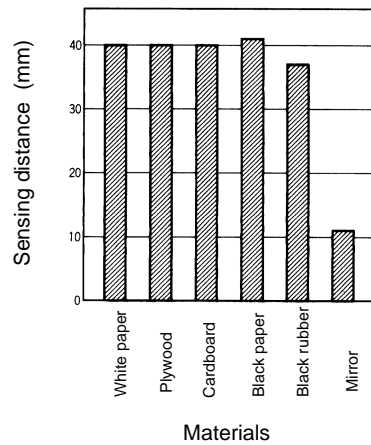

Sensing Distance vs. Materials (Typical)

E3S-LS10j

Sensing of White Paper at a Setting Distance of 100 mm

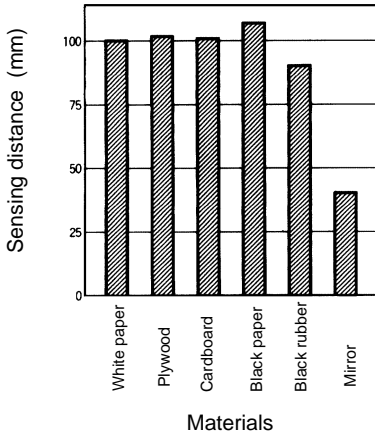

Sensing of White Paper at a Setting Distance 70 mm

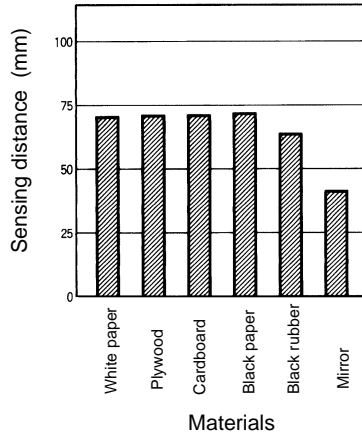

Sensing of White Paper at a Setting Distance 40 mm

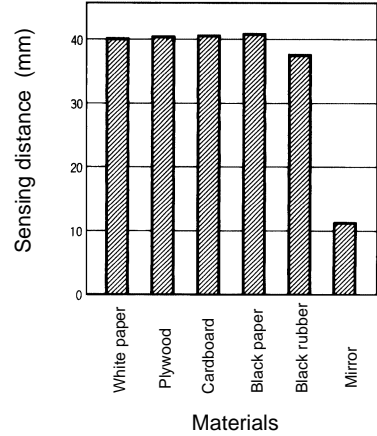

E3S-LS20j

Sensing of White Paper at a Setting Distance of 200 mm

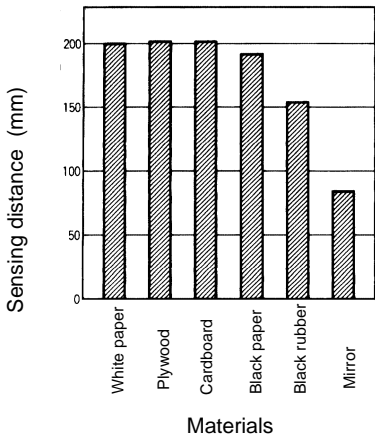

Sensing of White Paper at a Setting Distance 100 mm

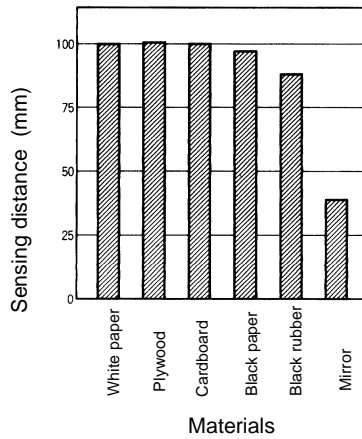

Sensing of White Paper at a Setting Distance 40 mm

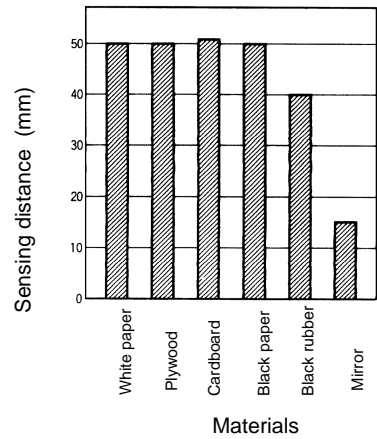

Note: The sensing distance will be shorter when sensing a mirror with little diffuse reflective light. A slanted mirror cannot be sensed.

Short Distance Characteristics (Typical)

E3S-LS5

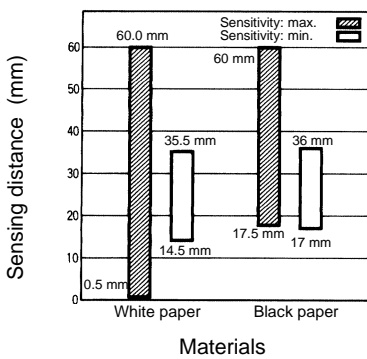

E3S-LS10

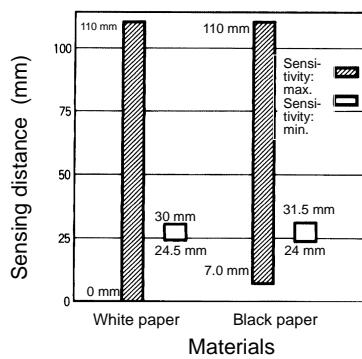

E3S-LS20

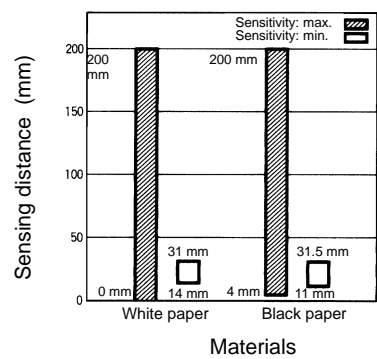

Operation

■ Circuit Diagram

Mode selection switch	Light-ON mode	Dark-ON mode																																																
Output	ON when object is near	ON when object is far																																																
E3S-LSj B4S1 (PNP) output circuit																																																		
E3S-LSj C4S (NPN) output circuit																																																		
Timing chart	<table border="0"> <tr> <td>Sensing object</td> <td>Near</td> <td></td> </tr> <tr> <td></td> <td>Far</td> <td></td> </tr> <tr> <td>Light incident indicator (red)</td> <td>ON</td> <td></td> </tr> <tr> <td></td> <td>OFF</td> <td></td> </tr> <tr> <td>Output transistor</td> <td>ON</td> <td></td> </tr> <tr> <td></td> <td>OFF</td> <td></td> </tr> <tr> <td>Relay, etc.</td> <td>ON</td> <td></td> </tr> <tr> <td></td> <td>OFF</td> <td></td> </tr> </table>	Sensing object	Near			Far		Light incident indicator (red)	ON			OFF		Output transistor	ON			OFF		Relay, etc.	ON			OFF		<table border="0"> <tr> <td>Sensing object</td> <td>Near</td> <td></td> </tr> <tr> <td></td> <td>Far</td> <td></td> </tr> <tr> <td>Light incident indicator (red)</td> <td>ON</td> <td></td> </tr> <tr> <td></td> <td>OFF</td> <td></td> </tr> <tr> <td>Output transistor</td> <td>ON</td> <td></td> </tr> <tr> <td></td> <td>OFF</td> <td></td> </tr> <tr> <td>Relay, etc.</td> <td>ON</td> <td></td> </tr> <tr> <td></td> <td>OFF</td> <td></td> </tr> </table>	Sensing object	Near			Far		Light incident indicator (red)	ON			OFF		Output transistor	ON			OFF		Relay, etc.	ON			OFF	
Sensing object	Near																																																	
	Far																																																	
Light incident indicator (red)	ON																																																	
	OFF																																																	
Output transistor	ON																																																	
	OFF																																																	
Relay, etc.	ON																																																	
	OFF																																																	
Sensing object	Near																																																	
	Far																																																	
Light incident indicator (red)	ON																																																	
	OFF																																																	
Output transistor	ON																																																	
	OFF																																																	
Relay, etc.	ON																																																	
	OFF																																																	

Note: Refer to the timing chart for the self-diagnostic output.

■ Self-diagnostic Output and Stability Indicator Display

E3S-LSj S Models

The self-diagnostic output of the E3S-LSj S will be ON when a sensing object is located in the unstable sensing area.

E3S-LSj S1 Models

The self-diagnostic output of the E3S-LSj S1 will be ON when a sensing object is located in the stable sensing area.

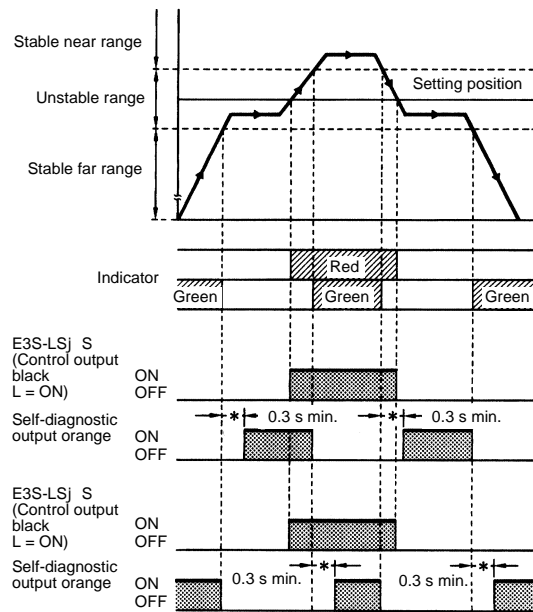

Note: *The E3S-LS has a 300-ms timer so the self-diagnostic output of the E3S-LS will not be always ON. When the E3S-LS is used to sense an object that takes more than 300 ms to pass through the sensing area, an appropriate external timer must be connected to the E3S-LS.

Dimensions

Note: All units are in millimeters unless otherwise indicated.

E3S-LS

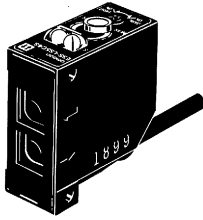

Cord: 4-dia., 0.12 dia. x 18,
4 cores
Standard length: 2 m

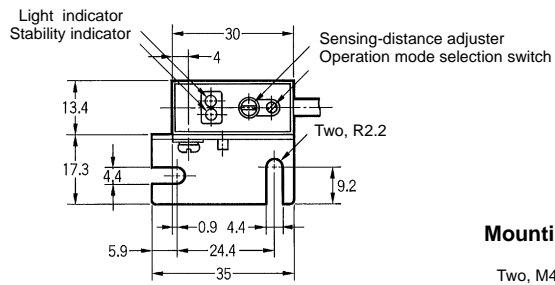

Mounting holes

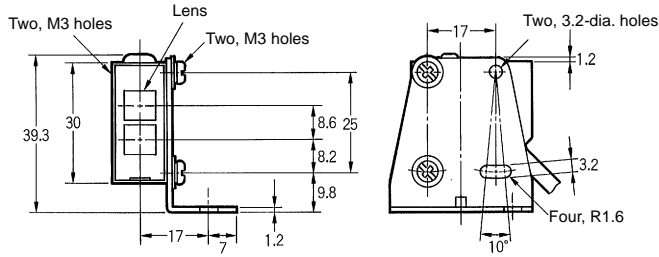
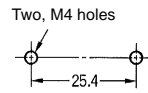

Installation

With S3D8 Sensor Controller

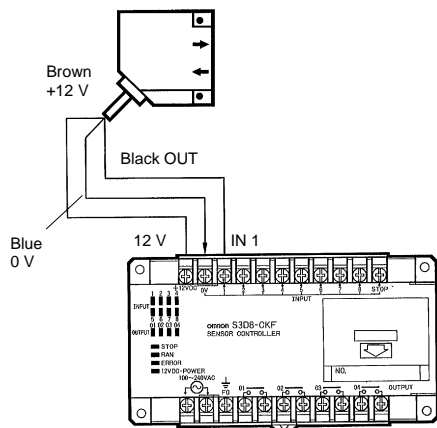

With S3D2 Sensor Controller

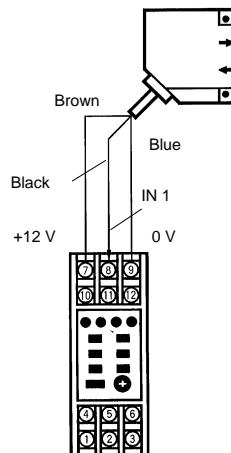

Precautions

Connections

Cords for the photoelectric switch should be laid through an independent conduit or a duct separated from power cables or 3-phase cables. Wiring power cables or 3-phase cables laid alongside cords for the photoelectric switch in the same conduit or duct can result in malfunction or damage to the photoelectric switch due to induction.

Use a connection cord with a thickness of 0.3 mm^2 . The maximum allowable length is 100 m.

Do not hit the photoelectric switch with a hammer or other tools at the time of installation. The switch's watertight seal may be broken.

If the self-diagnostic output function is not required, cut the orange lead wire down to appropriate length and protect the wire with insulating tape so that the wire cannot contact with other terminals.

Power Supply

When using a standard switching regulator, ground the FG (frame ground) terminal or the G (ground) terminal. Failure to do so will result in malfunction due to switching noise.

Watertightness

The enclosure rating level is IEC IP67. However, avoid use in water or outdoors.

Installation

Clamp the case with a torque of 5 kgf 5 cm maximum.

Do not install the photoelectric switch at an angle that will allow strong sunlight, fluorescent light, or incandescent lit to enter it

The installing direction of the photoelectric switch should be determined in consideration of the direction of movement of the sensing objects.

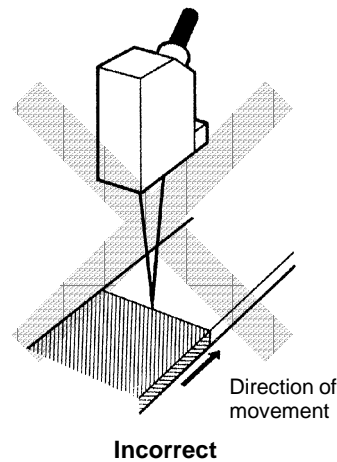
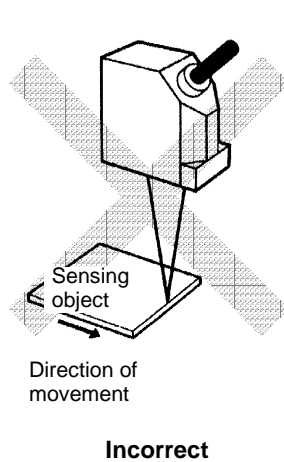
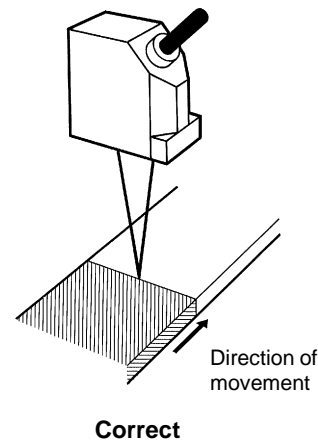
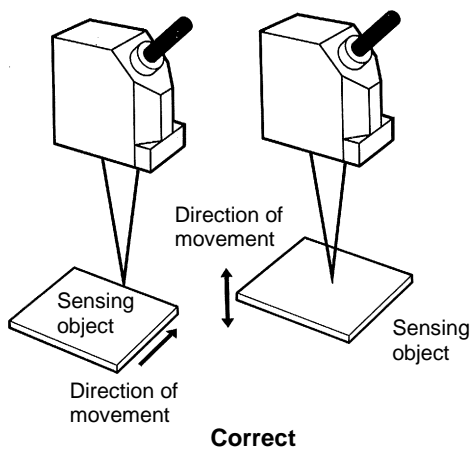

ALL DIMENSIONS SHOWN ARE IN MILLIMETERS.

To convert millimeters into inches, multiply by 0.03937. To convert grams into ounces, multiply by 0.03527.

Cat. No. E208-E1-2 **In the interest of product improvement, specifications are subject to change without notice.**

OMRON Corporation

Systems Components Division H.Q.
28th Fl., Crystal Tower Bldg.
1-2-27, Shiromi, Chuo-ku,
Osaka 540 Japan
Phone: 06-949-6012 Fax: 06-949-6021

Printed in Japan
0296-1M (0890) a