

DESCRIPTION

Solenoid valve 3-way
direct acting poppet type

CONSTRUCTION

Body	Brass
Armature Tube	Brass
Armature & Core	Stainless steel
Spring	Stainless steel
Seal material	NBR FPM EPDM

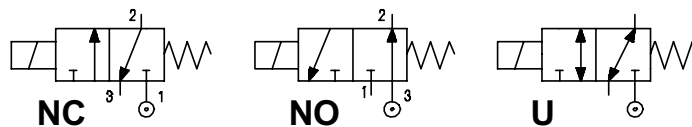
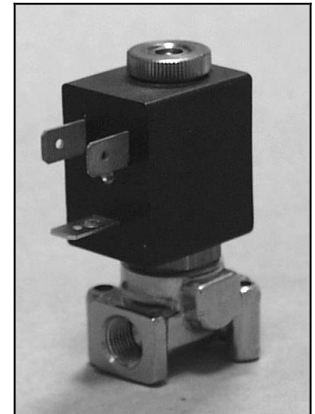

FEATURES

- Maximum allowable pressure: maximum differential pressure +10%
- Maximum fluid viscosity 25cSt (mm²/s)
- Ambient temperature : with class F coil -10° +55°C
with class H coil -10°+80°C
- Universal mounting position

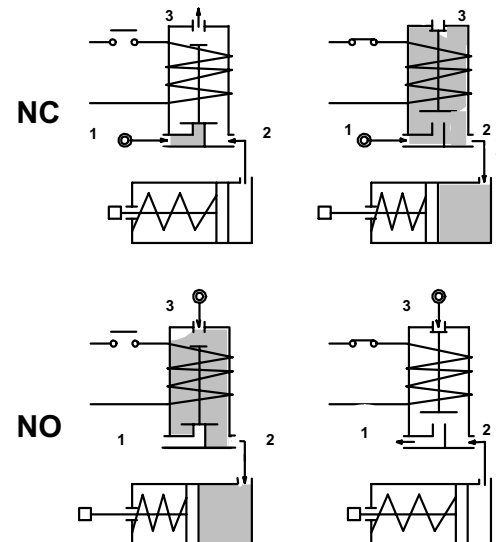

OPTIONS :

- Manual override
- Electroless nickel plating
- Explosion proof coil to ATEX-EEExmII Type 7
- Stainless steel armature tube
- Exhaust port with hosetail connection

CODE ① ②	Connection G	Orifice mm		KV m ³ /h	Differential pressure bar			Nominal Power			Coil		Seal ①	Temp. range C°
		inlet	exh.		Min	Max		AC Inrush	VA Holding	DC Watt	Type	Width		
						AC	DC							
NC Normally closed														
E305A.....12///.....	1/8"	1.2	1.5	0.04	0	15	15	12	8	6.5	3	22	NBR=B EPDM=E FPM=V	-10 +90 <+140 -10 +130
E305A.....15///.....	1/8"	1.5	1.5	0.06	0	10	10	12	8	6.5	3	22		
E305A.....20///.....	1/8"	2	1.7	0.09	0	6	6	12	8	6.5	3	22		
NO Normally open														
E305A.....15/S/.....	1/8"	1.5	1.5	0.06	0	10	10	12	8	6.5	3	22	NBR=B EPDM=E FPM=V	-10 +90 <+140 -10 +130
E305A.....17/S/.....	1/8"	1.7	2	0.07	0	6	6	12	8	6.5	3	22		
U Universal														
E305A.....15/G/.....	1/8"	1.5	1.5	0.06	0	6	6	12	8	6.5	3	22		

3.305.A/03/05

- ① Seal
- ② Coil

Example E305AV15///30B FPM seal 24V 50Hz NC
E305 AB15/S/301 NBR seal 24V DC NO

COIL	Alternating current ~50 /60Hz Volt							Direct current Volt			Electrical Connection	Connector
	12	24	48	110	220 230	240	380	12	24	48		
Type 3 Width 22 Code ②	30A	30B	30C	30D	30E	30F	30G	300	301	302	DIN 46244	PG9 code 10348000

DESCRIPTION
 Class F insulation
 Voltage tolerance
 AC +15% -10%
 DC ± 10%
 Protection to IP65
 with connector fitted
 IP00 without connector
 Continuous service
 ED100%

OPTIONS
 Class H insulation
 Cable attached
 Special coil voltage
 and power

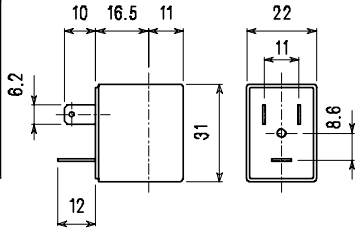
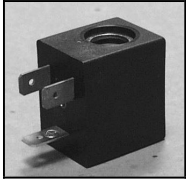

Type 3 Weight 0.05Kg

SPARE PARTS LIST

- 1.Coil fixing nut
- 2.Coil
- 3.Armature assembly
- 4.Armature tube with core

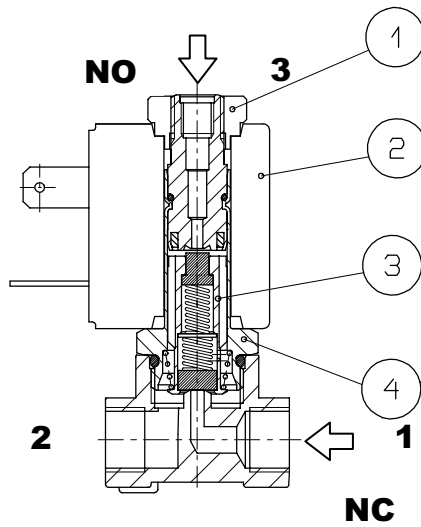

MANUAL OVERRIDE

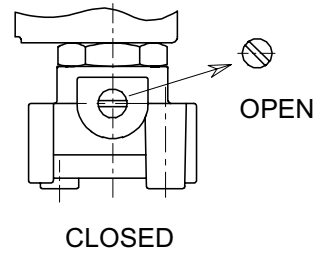

OVERALL DIMENSION

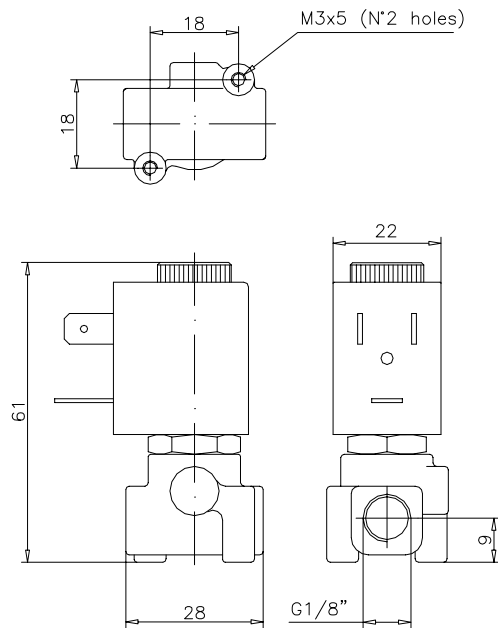

Weight 0.13 Kg